

Power Factor Correction and Power System Harmonics

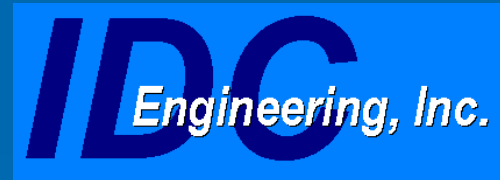

Eric Zobel
Myron Zucker, Inc.



Julie VanDyne, P.E.
IDC Engineering, Inc.

Power Quality

Power Factor Correction

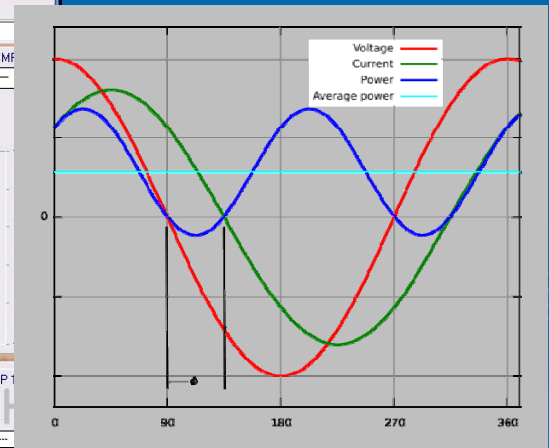
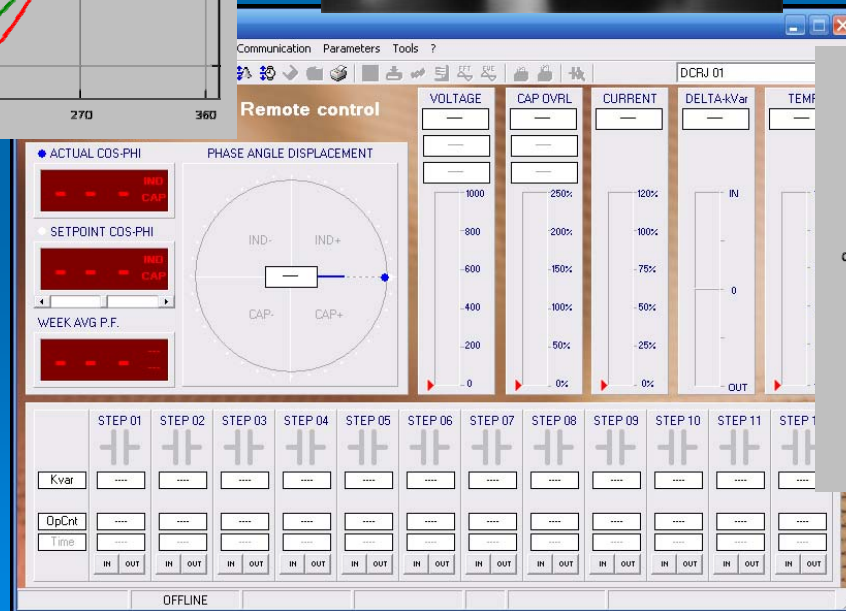
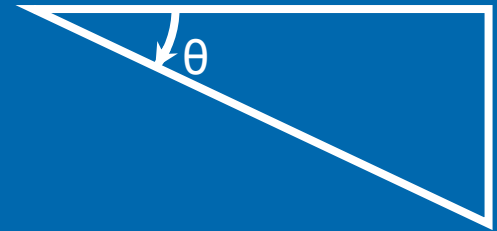
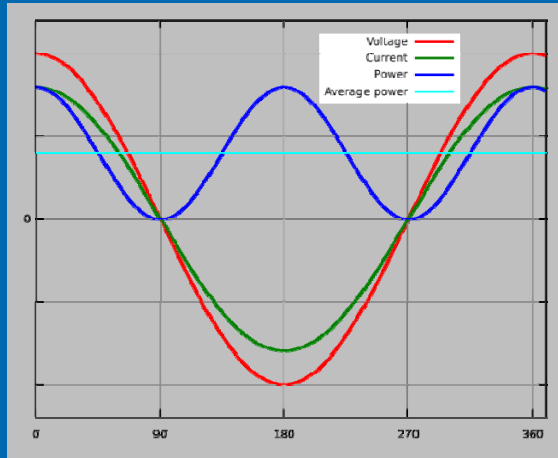

Power Factor

Power Factor 101-

- Wikipedia's definition of power factor
- The different views of power factor
- Who pays for a poor power factor
- The simple way to correct a poor power factor
- Correction "at-the-main" or "at-the load"
- Simple is not always simple

Power Factor Defined

Wikipedia's definition of Power Factor

- The power factor of an AC electric power system is defined as the ratio of the real power to the apparent power, and is a number between 0 and 1 (frequently expressed as a percentage, e.g. 0.5 pf = 50% pf).

Real power?

Apparent power?!

Power Factor Defined

Power, power, who's got the power?

Active
Apparent
Real
Total
Reactive
Working
Imaginary
kW
kVA
kVA_r



Power Factor Defined

The power factor triangle helps us all be on the same page -

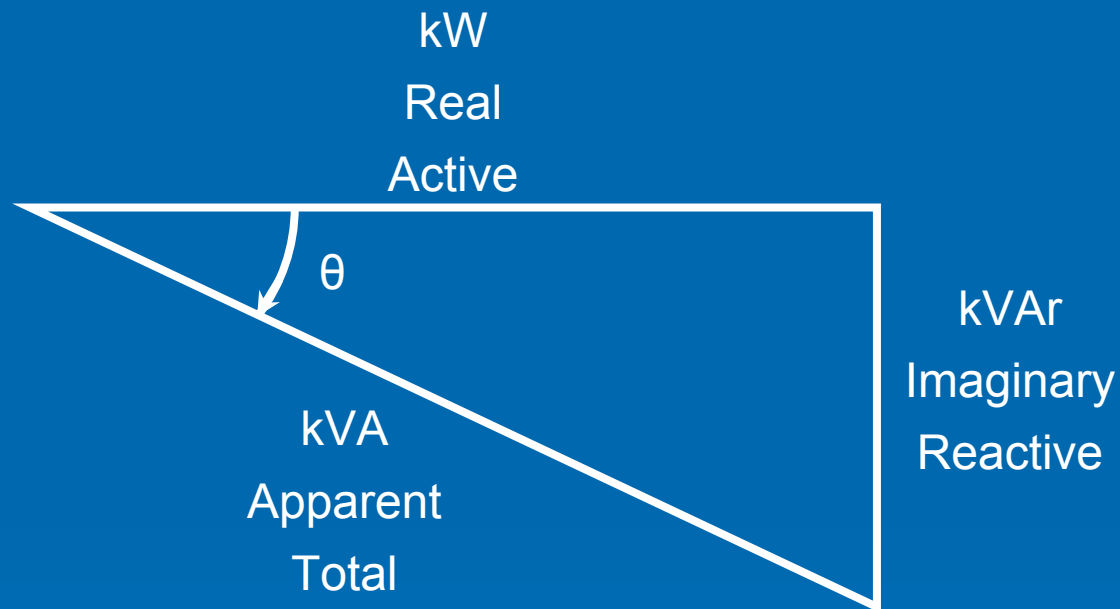

$$\text{pf} = \text{kW} / \text{kVA}$$

when kVA is unknown:

$$\arctan (\text{kVAr} / \text{kW}) = \theta$$

$$\text{pf} = \cos \theta$$

Note:
arctan on a calculator
is shown as \tan^{-1}



A simple view of power



MOTOR



Inductive loads require two kinds of power to operate:

- **Active Power (kW)**
 - *Actually performs the work*
- **Reactive Power (kVAR)**
 - *Maintains the electro-magnetic field*
- **Apparent Power (kVA)**
 - *Total power (vector sum of active and reactive power)*

Not an imaginary power

Warning: Reactive power (kVAr) may cause side-effects:
Symptoms may include leading power factor - a.k.a. the ICE.
Common side-effects entail a lagging power factor – a.k.a. the ELIs.

ICE – current (I) in a capacitive system (C) leads voltage (E)

ELI – voltage (E) in an inductive system (L) leads current (I)

Or CIVIL

CIV – Capacitance (C) makes current (I) lead voltage (V)

VIL – Voltage (V) leads current (I) in inductance (L)



Show me a sine!

The sine wave in a perfect world –

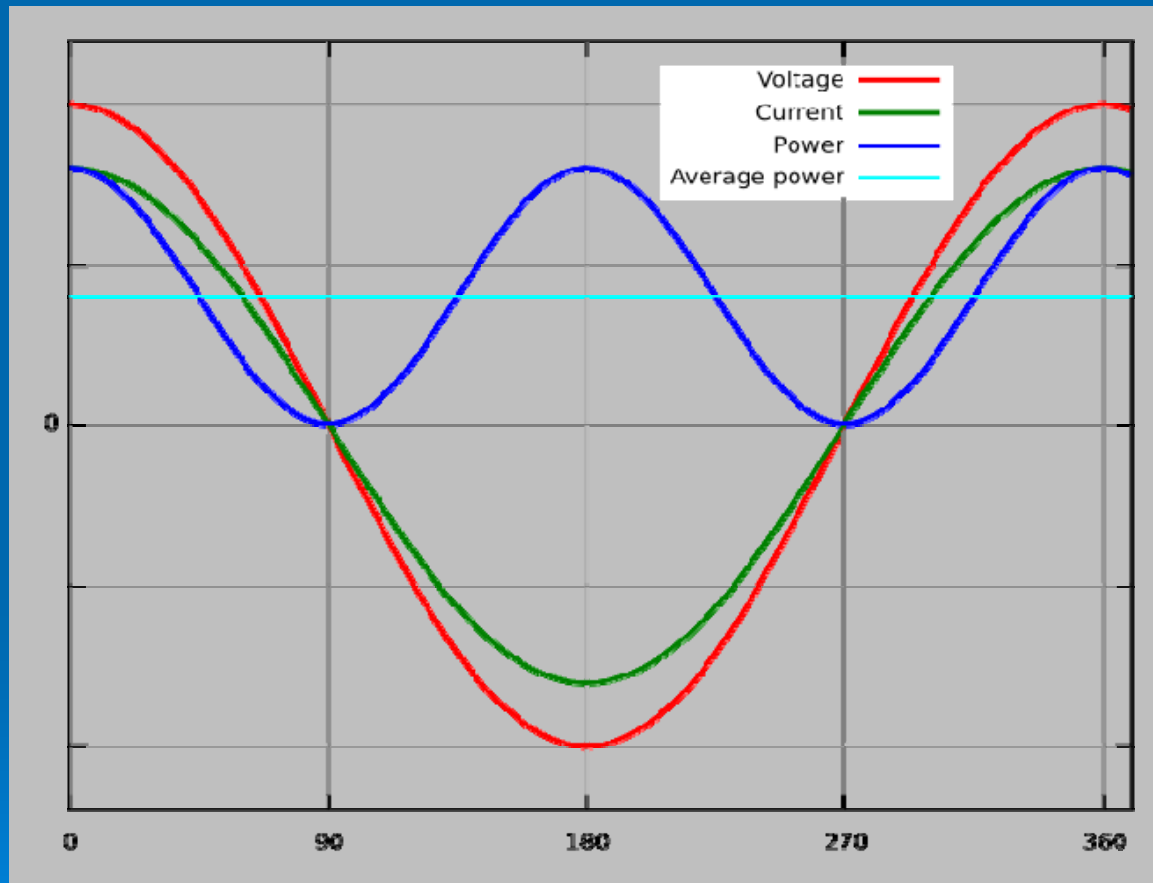

In a perfect world kVA would equal kW
and kVAr would always total zero

Show me a sine!

The sine wave in an almost real world –

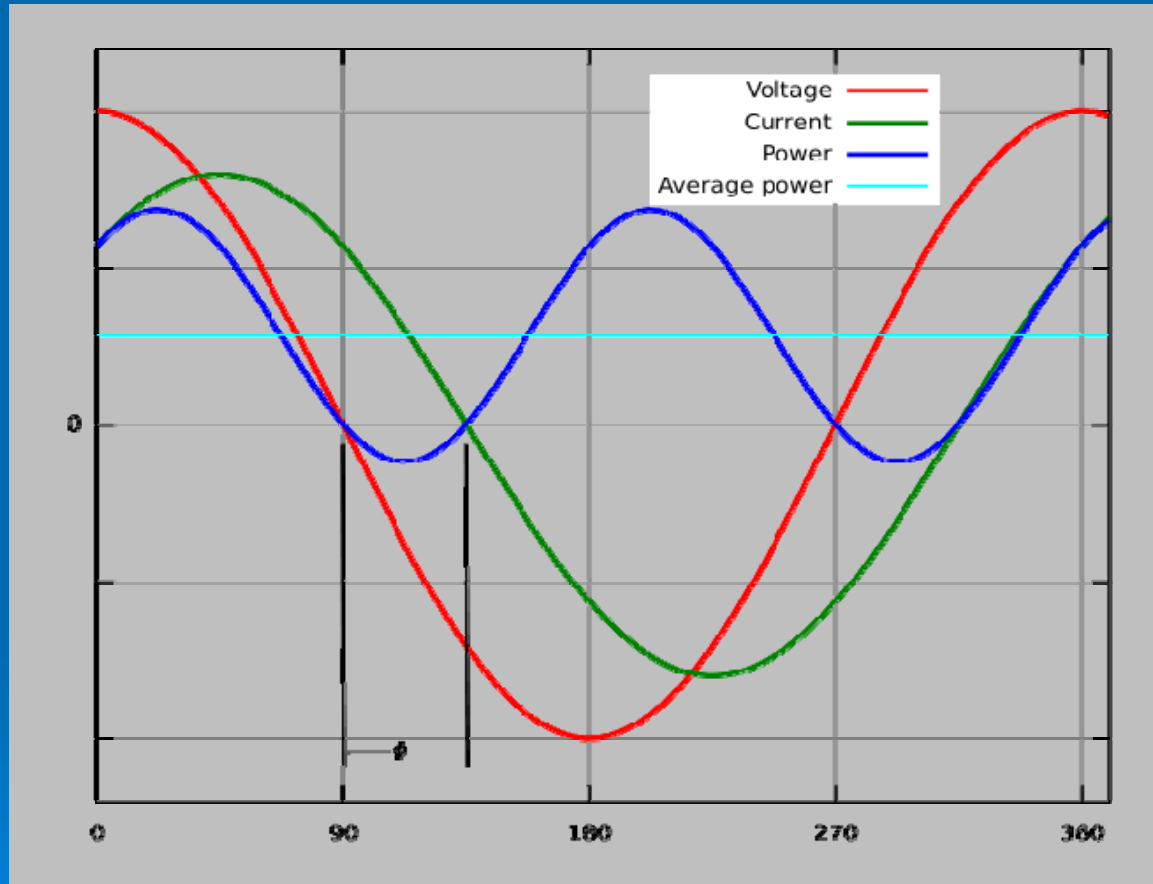

In the real world kVA will be greater than kW
and kVAr rarely totals zero

Why worry about power factor?

Answer in a nutshell –

Poor power factor wastes resources for the utility and the end user.

- Decreases grid capacity
- Loads transformers with reactive power
- Increases line (I^2R) losses

Where you can find poor power factor?

Device	Power Factor
Incandescent Lights	0.99+
Resistive Heating	0.99+
Air Handler Motor	0.80
Saw Mill Motor	0.50

Low power factor typically results when motors are operated at significantly less than full load. Other examples of motors with low power factor:

- Conveyors
- Compressors
- Grinders
- Punch Presses

Who pays for poor power factor?

Everyone –

In one way or another we all pay for poor power factor but only the large offenders pay an actual power factor penalty. With power factor minimums ranging from .80 all the way up to .95 across the U.S. those penalties can vary greatly from state to state as well as utility to utility.

Who pays for poor power factor?

In the DTE service area a .849 power factor will result in a 1% adder to your electric bill. Below are tables, from the DTE website, to help customers understand power factor penalty costs.

For a mid-size Primary Service Customer:

% Power Factor Penalty	1%	2%	3%	25%
Monthly Electric Bill	\$17,500	\$17,500	\$17,500	\$17,500
Monthly Power Factor Penalty	\$175	\$350	\$525	\$4,375
Estimated Cost to Correct	\$5,500	\$6,875	\$8,800	\$11,000
Simple Payback (months)	31	20	17	3

For a large-size Primary Service Customer:

% Power Factor Penalty	1%	2%	3%	25%
Monthly Electric Bill	\$100,000	\$100,000	\$100,000	\$100,000
Monthly Power Factor Penalty	\$1,000	\$2,000	\$3,000	\$25,000
Estimated Cost to Correct	\$6,875	\$9,075	\$11,000	\$17,875
Simple Payback (months)	7	5	4	1

The simple way to correct

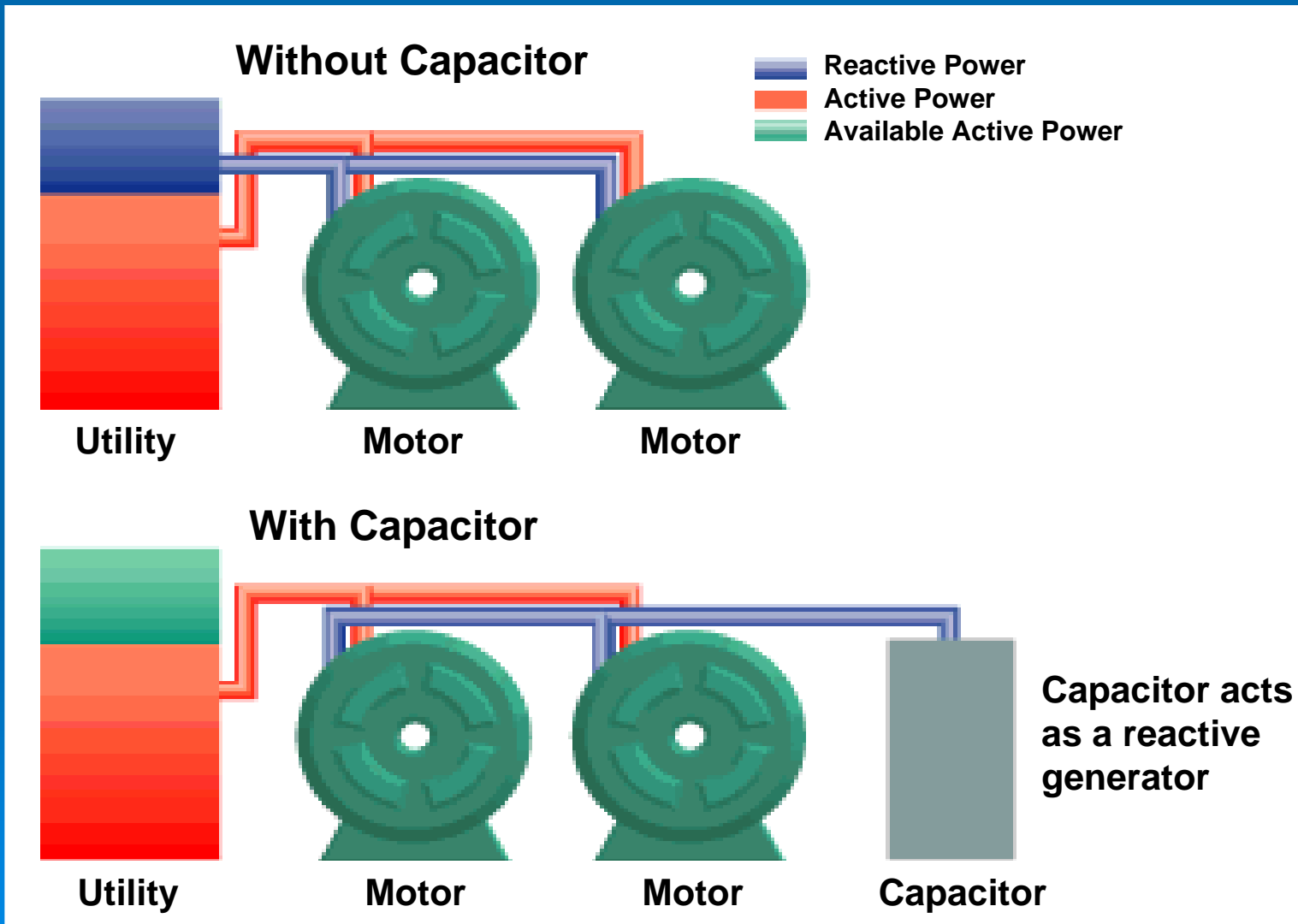

The simple way to correct

How much kVAr do I need?

The kVAr requirements will depend on the present power factor, the desired power factor and the kilowatt usage. Just plug those numbers in to this simple formula -

$$\text{kVAr} = \text{Kilowatts} \times \left[\sqrt{\frac{1 - \text{PF}_0^2}{\text{PF}_0^2}} - \sqrt{\frac{1 - \text{PF}_T^2}{\text{PF}_T^2}} \right]$$

A simpler way to correct

Example using a power factor table-

The utility bill shows a power factor of 0.72 with an average KW of 627. How much kVAr is required to improve power factor to 0.95?

Using the PF Multiplier Table (next slide)

1. Locate 0.72 (original PF) in column 1.
2. Read across desired PF to 0.95 column, intersect at 0.635
3. Multiply 627 (average KW) by 0.635 = 398 kVAr
4. Install 400 kVAr to improve PF to 95%

A simpler way to correct

Use the tables-

		Desired Power Factor (%)												
		<u>80</u>	<u>85</u>	<u>90</u>	<u>91</u>	<u>92</u>	<u>93</u>	<u>94</u>	<u>95</u>	<u>96</u>	<u>97</u>	<u>98</u>	<u>99</u>	<u>100</u>
Original Power Factor (%)	<u>68</u>	0.328	0.459	0.594	0.623	0.652	0.683	0.715	0.750	0.787	0.828	0.875	0.936	1.078
	<u>69</u>	0.299	0.429	0.565	0.593	0.623	0.654	0.686	0.720	0.757	0.798	0.846	0.907	1.049
	<u>70</u>	0.270	0.400	0.536	0.565	0.594	0.625	0.657	0.692	0.729	0.770	0.817	0.878	1.020
	<u>71</u>	0.242	0.372	0.508	0.536	0.566	0.597	0.629	0.663	0.700	0.741	0.789	0.849	0.992
	<u>72</u>	0.214	0.344	0.480	0.508	0.538	0.569	0.601	0.635	0.672	0.713	0.761	0.821	0.964
	<u>73</u>	0.186	0.316	0.452	0.481	0.510	0.541	0.573	0.608	0.645	0.686	0.733	0.794	0.936
	<u>74</u>	0.159	0.289	0.425	0.453	0.483	0.514	0.546	0.580	0.617	0.658	0.706	0.766	0.909
	<u>75</u>	0.132	0.262	0.398	0.426	0.456	0.487	0.519	0.553	0.590	0.631	0.679	0.739	0.882
	<u>76</u>	0.105	0.235	0.371	0.400	0.429	0.460	0.492	0.526	0.563	0.605	0.652	0.713	0.855
	<u>77</u>	0.079	0.209	0.344	0.373	0.403	0.433	0.466	0.500	0.537	0.578	0.626	0.686	0.829
	<u>78</u>	0.052	0.183	0.318	0.347	0.376	0.407	0.439	0.474	0.511	0.552	0.599	0.660	0.802
	<u>79</u>	0.026	0.156	0.292	0.320	0.350	0.381	0.413	0.447	0.484	0.525	0.573	0.634	0.776
	<u>80</u>	0.000	0.130	0.266	0.294	0.324	0.355	0.387	0.421	0.458	0.499	0.547	0.608	0.750
	<u>81</u>		0.104	0.240	0.268	0.298	0.329	0.361	0.395	0.432	0.473	0.521	0.581	0.724
	<u>82</u>		0.078	0.214	0.242	0.272	0.303	0.335	0.369	0.406	0.447	0.495	0.556	0.698
	<u>83</u>		0.052	0.188	0.216	0.246	0.277	0.309	0.343	0.380	0.421	0.469	0.530	0.672
	<u>84</u>		0.026	0.162	0.190	0.220	0.251	0.283	0.317	0.354	0.395	0.443	0.503	0.646
<u>85</u>		0.000	0.135	0.164	0.194	0.225	0.257	0.291	0.328	0.369	0.417	0.477	0.620	

“At-the-Main” or “At-the-Load”?

Our example needs 400 kVAr installed to reach their desired power factor. So where do we install it?

We could install a 400 kVAr automatic capacitor bank at the main service entry.

We could install several small capacitor at the loads that would total 400 kVAr.

The facility layout will usually determine the application of the kVAr.

Both “at-the-main” and “at-the-load” may be used simultaneously in the facility.



“At-the-Main” or “At-the-Load”?

“At-the-main” and “at-the-load” capacitor applications have advantages and disadvantages.

Those factors include –

- Installation costs
- Equipment costs
- System flexibility
- Line (I^2R) losses
- Harmonics



Simple is not always simple

When it comes to capacitors that statement can be boiled down to one word –

Harmonics

Now for the fun stuff!



The Hand Off

Thank you for letting me present the power factor portion of today's seminar and now I turn the floor over to Julie VanDyne for the harmonic portion.



Eric Zobel
Myron Zucker, Inc.
36825 Metro Court
Sterling Heights, MI
ezobel@myronzucker.com
www.myronzucker.com

Julie VanDyne P.E.
IDC Engineering, Inc.
1755 Shawnee Rd., #301
Lima, Ohio 45805
jvandyne@idcengr.com
www.idcengr.com

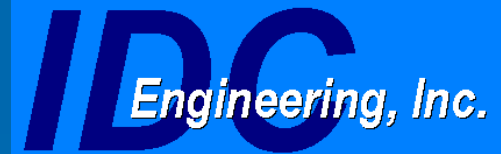

Power Quality Harmonics

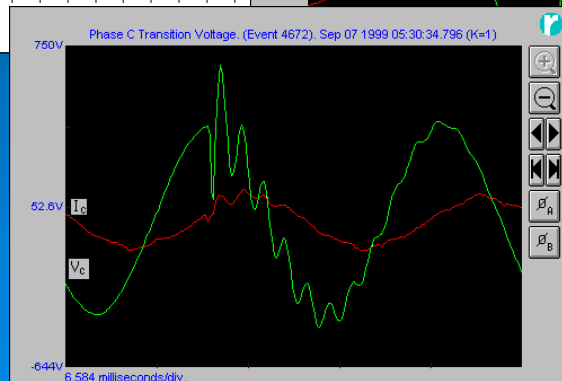
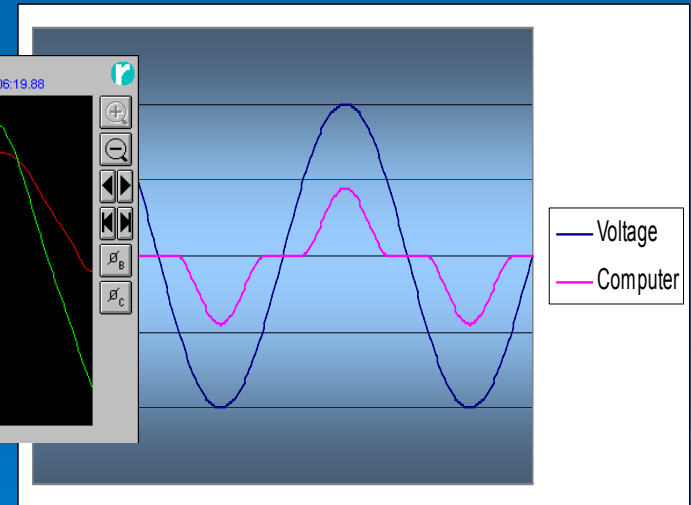
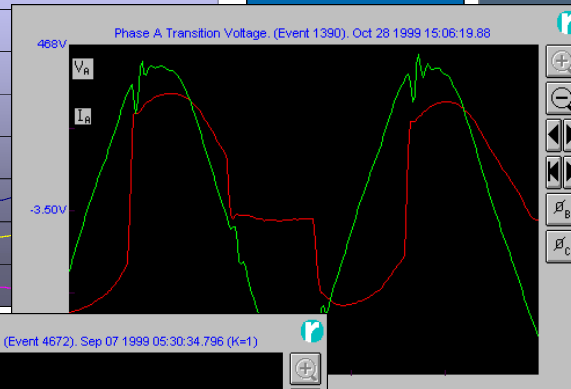
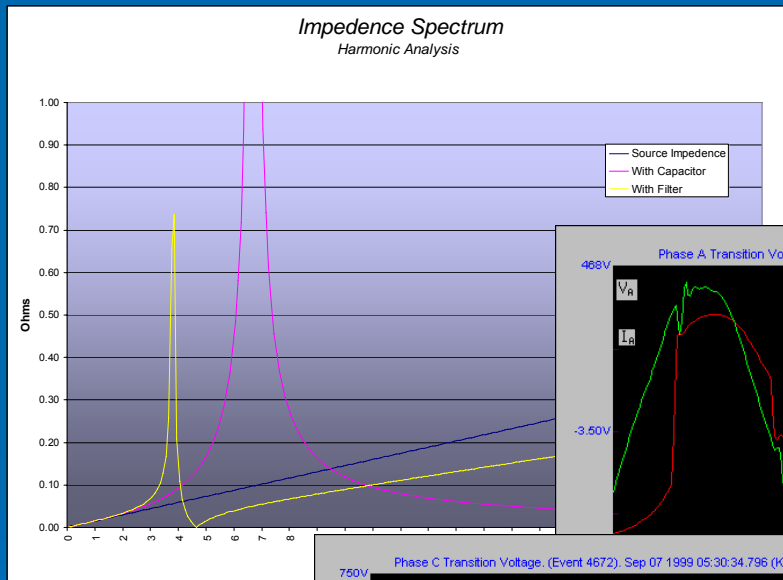

Capacitance/Power Quality

- Up to now, we've talked about power factor and power factor correction
- Adding capacitance changes the supply system impedance
- The change in impedance can lead to harmonic resonance problems
- Resonance is not just a steady state problem, but worse, a **transient** problem!

Harmonics

Harmonics

- Define what they are
- How they come about in Power Systems
- Characteristics of Individual Harmonics
- Motor Drive Systems
- Effects on power systems - Consequences

Harmonics

Primer

Fourier - French Mathematician

Describe any waveshape as the sum of a fundamental sinusoidal wave and an infinite series of harmonic sinusoidal waves

Fundamental
Waveshape

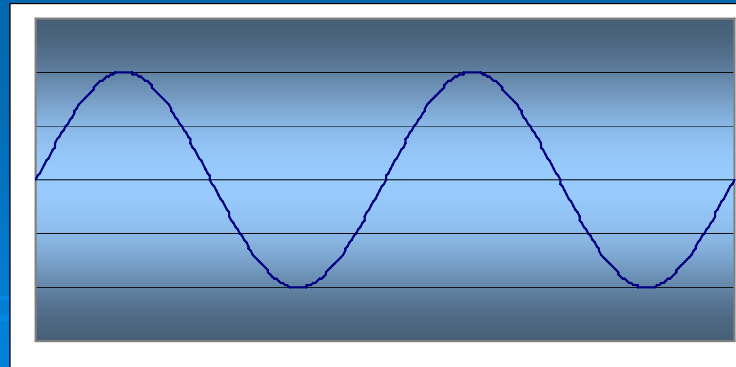

Harmonics

Fundamental and Third Harmonic

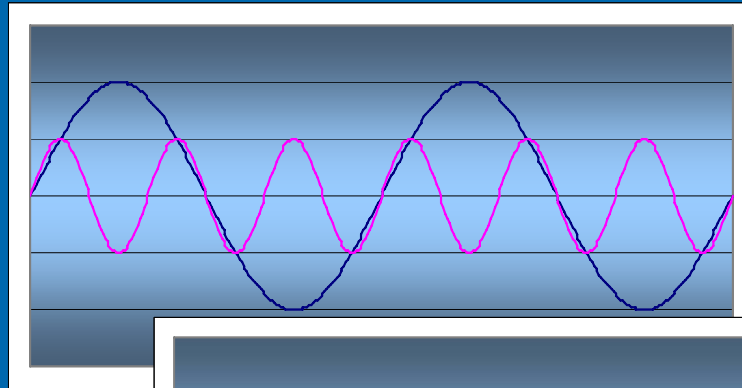

Fundamental and Fifth Harmonic

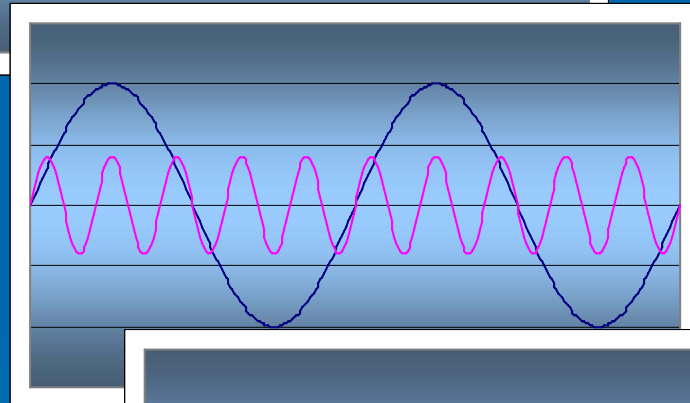

Fundamental and Seventh Harmonic

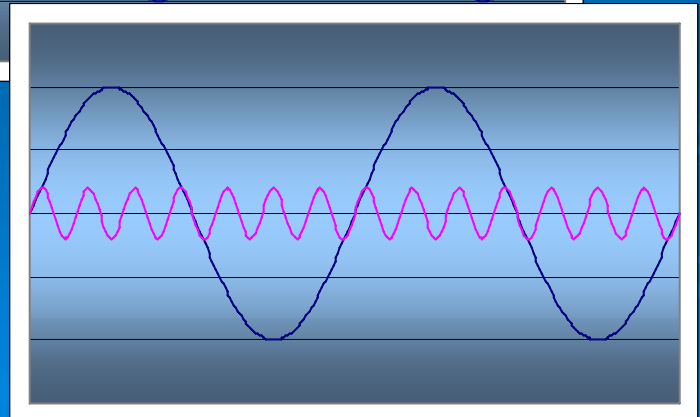

Harmonic Distortion

Fundamental Minus Third Harmonic

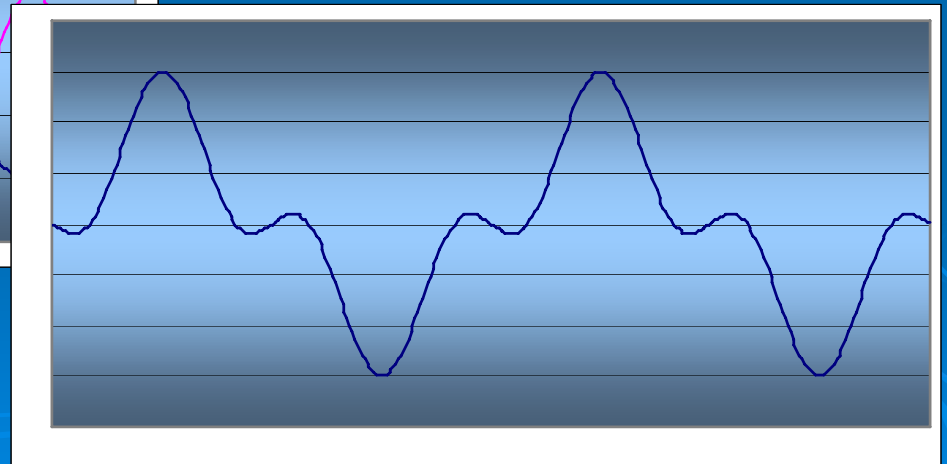
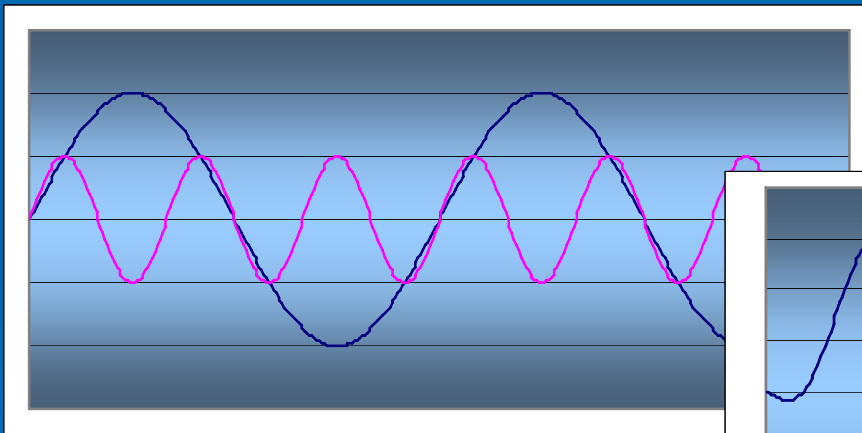

Harmonics

Linear vs. Non Linear Loads

Linear

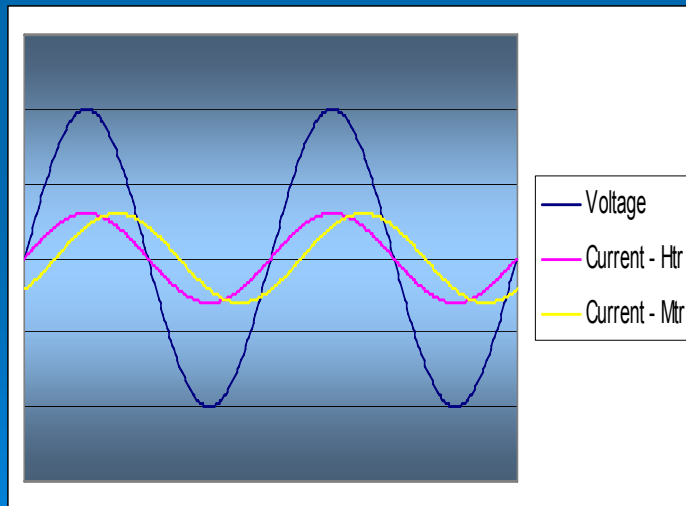

Non - Linear

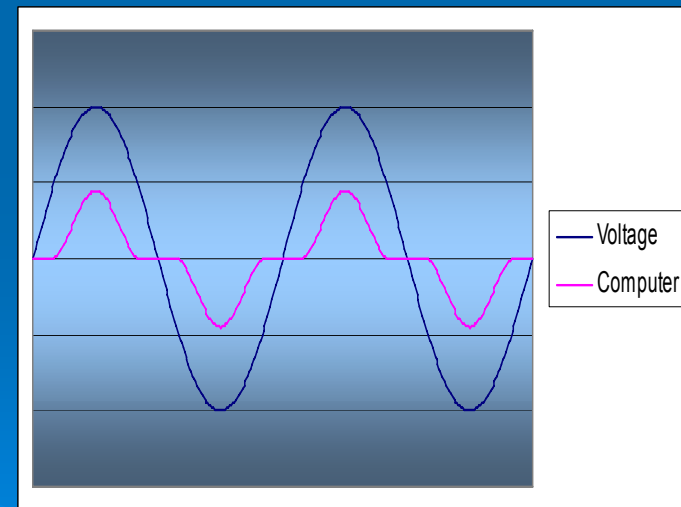

Harmonics

Switching Mode Power Supply

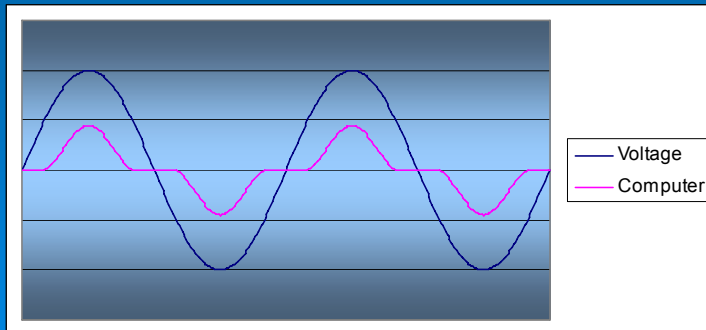
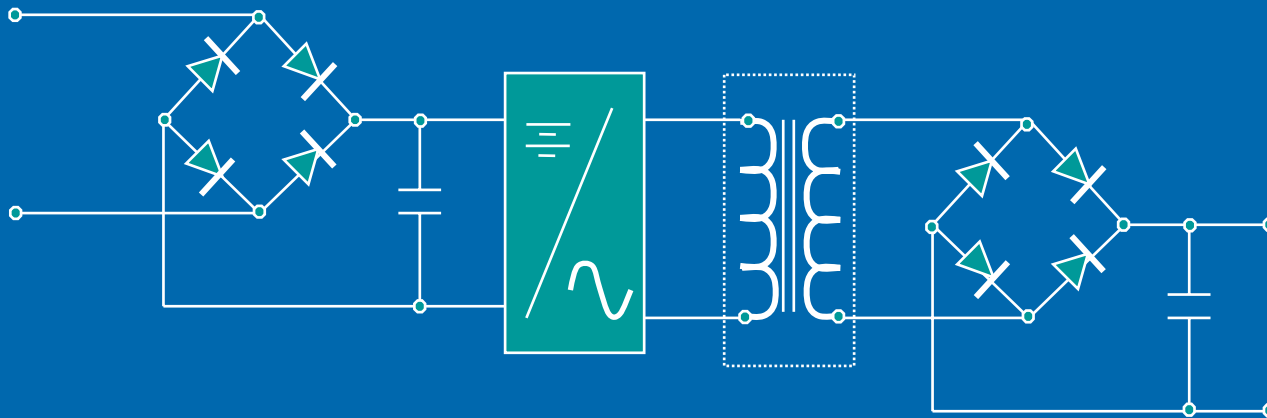

Harmonics

- Linear Load \Rightarrow Linear Voltage Drop
 - No Waveshape Distortion
- Non Linear Loads \Rightarrow Non Linear Voltage Drop
 - Waveshape Distortion

Harmonics

Linear Vs. Non-Linear

Load (I) and Source (V)
(Combined System Impedance
(Z))

Ohms Law

$$E = I * Z$$

Distorted Voltage Waveform -
Voltage Drop at the Third
Harmonic

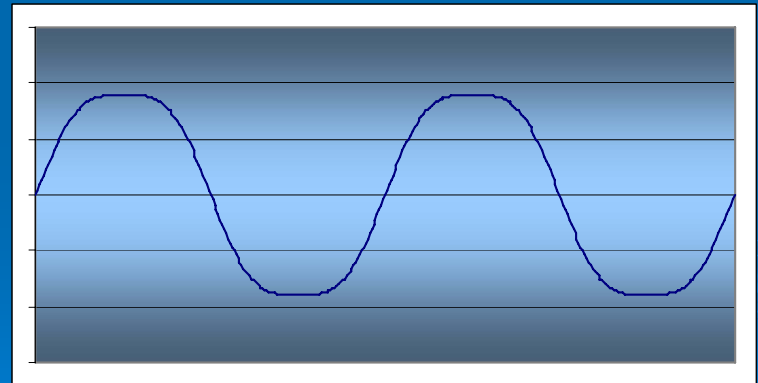
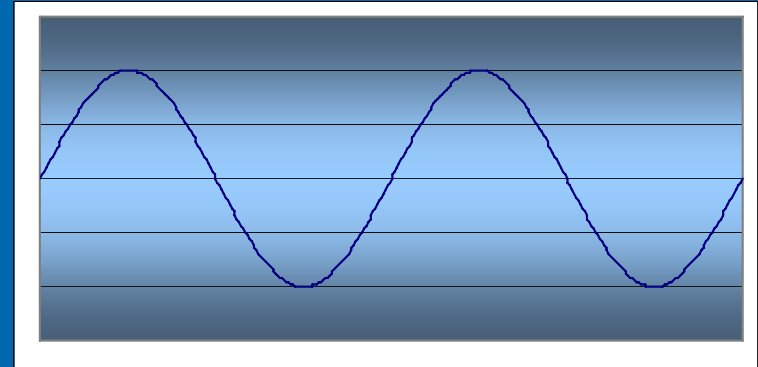

Drive Harmonics

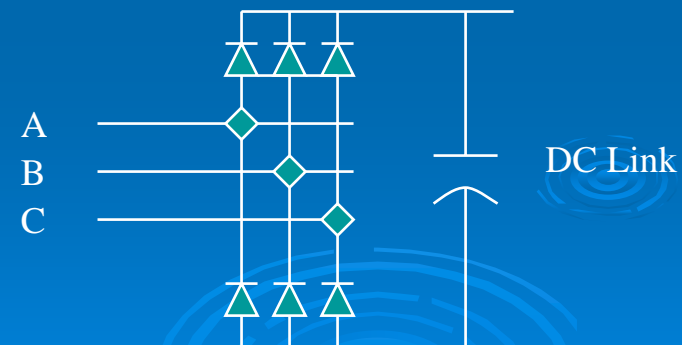
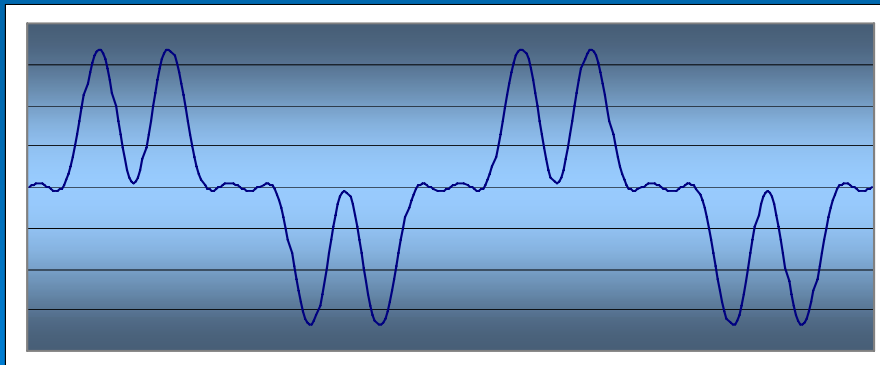
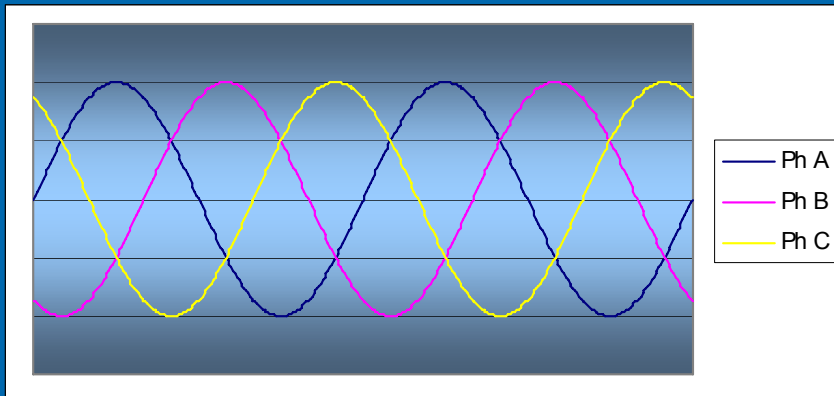

Harmonic Distortion

Fundamental With Voltage Drop at the Fifth and Seventh Harmonic

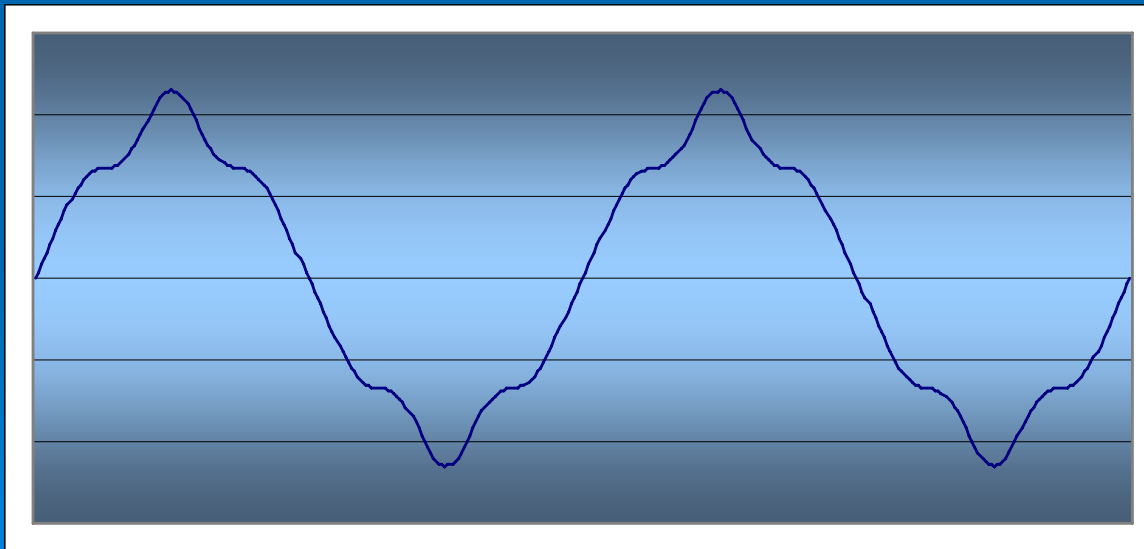

Harmonic Rotation

Fundamental

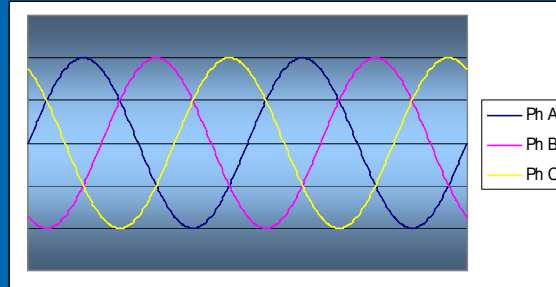

Third Harmonic

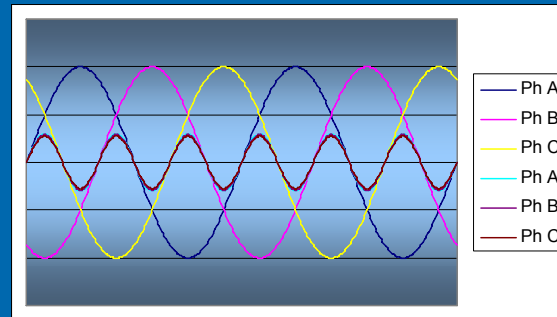

Fifth Harmonic

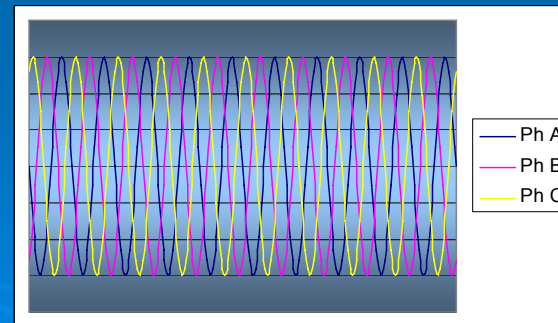

Harmonic Rotation

➤ Fundamental	Positive
➤ Second	Negative
➤ Third	Zero
➤ Fourth	Positive
➤ Fifth	Negative
➤ Sixth	Zero
➤ Seventh	Positive
➤ Eighth	Negative
➤ Ninth	Zero
➤ Tenth	Positive
➤ Eleventh	Negative
➤ Twelfth	Zero
➤ Thirteenth	Positive
➤ Fourteenth	Negative
➤ Fifteenth	Zero

Consequences

➤ Motors

- Reverse Torque
- Overheating
- Shortened life

➤ Transformers

- Increased Losses
- Overheating
- Shortened life

➤ Capacitors

- Increased Current
- Overheating
- Shortened life

➤ Plant Electronics

- Misoperation
- Failure
- Downtime

Distortion Levels

IEEE 519-1992

- All Harmonics - Voltage (THD) <5% (<10%) for STEADY STATE
- Problems often show up as TRANSIENTS

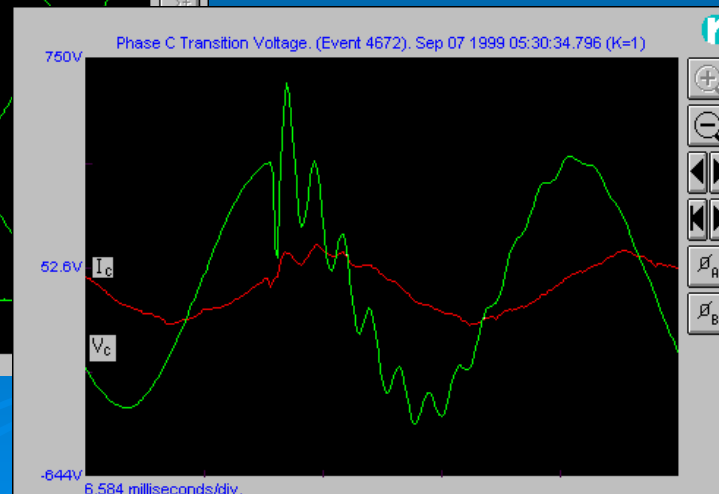
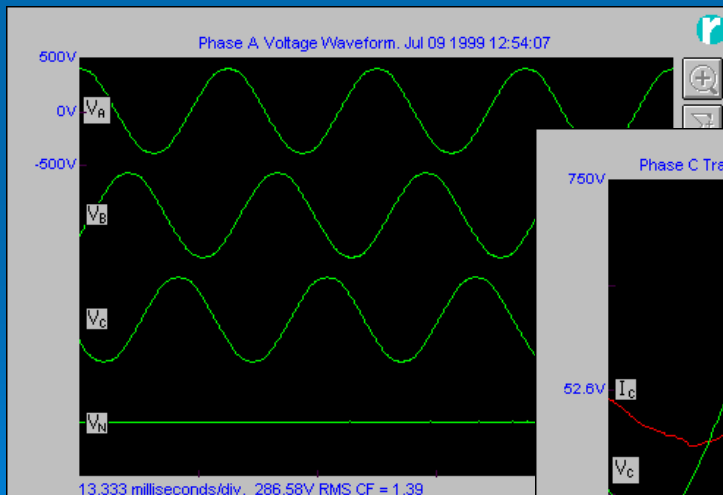

Harmonics

➤ Review

- Harmonics are a way to describe the result of non-linear loads on the power system
- Basic Limit of 5% (10%) for Voltage Distortion
- Current Distortion Limit Depends on System, Currently under review

Source Issues

- So Far - Only Load Issues
- Source Impedance has been assumed to be constant/linear

Source Issues

- Look at the Source of our loads
 - Determine its characteristics
 - How these characteristics impact the Distortion Equation
 - How we can affect the characteristics
 - Filtering
 - Capacitors/Ratings/Issues

Source Issues

Source Impedance
Graph

Transformer
Impedance only

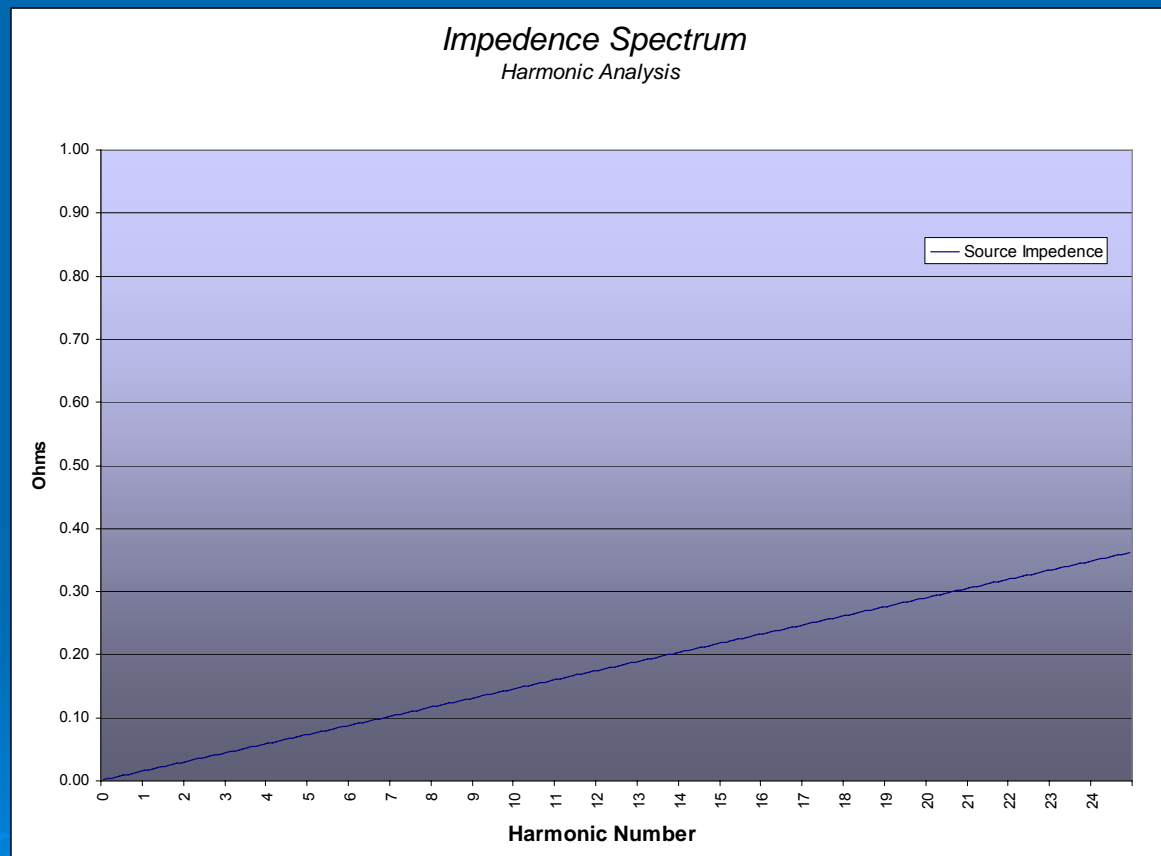

Source Issues

Thevenin Equivalent
Circuit

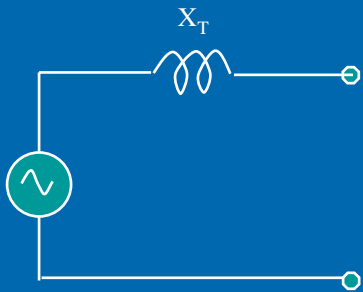

Norton Equivalent
Circuit

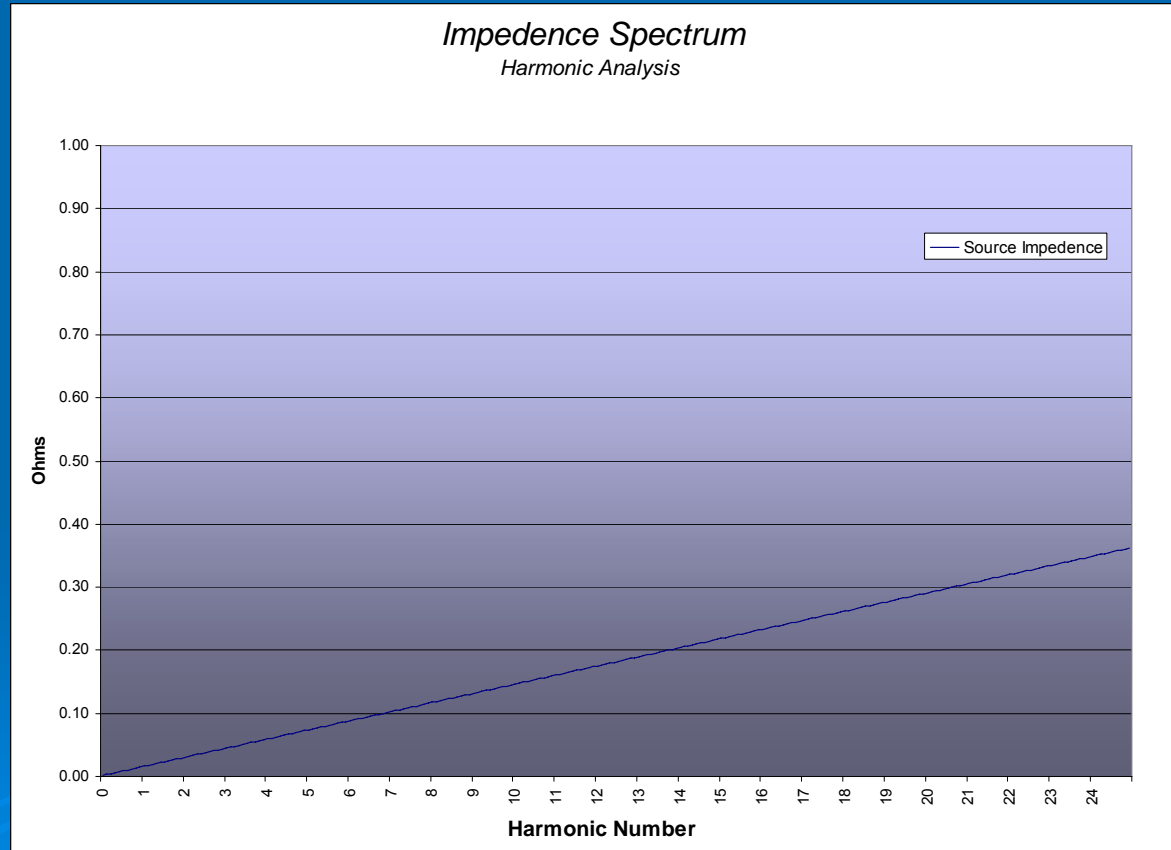
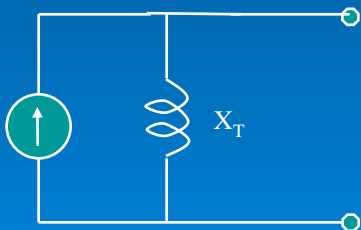

Source Issues

Norton Equivalent Circuit

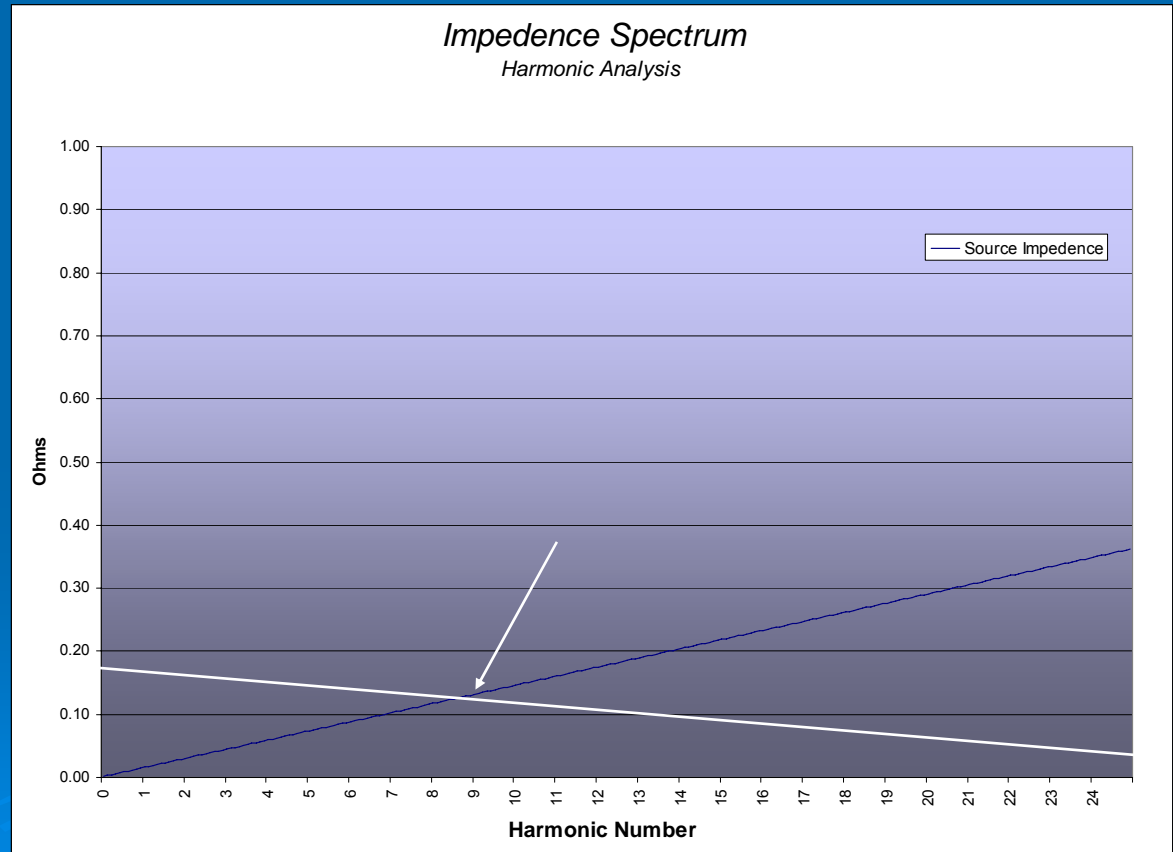
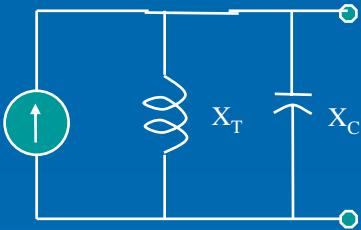

Source Issues

Norton
Equivalent Circuit

$$Z_s = \frac{X_T * X_C}{X_T + X_C}$$

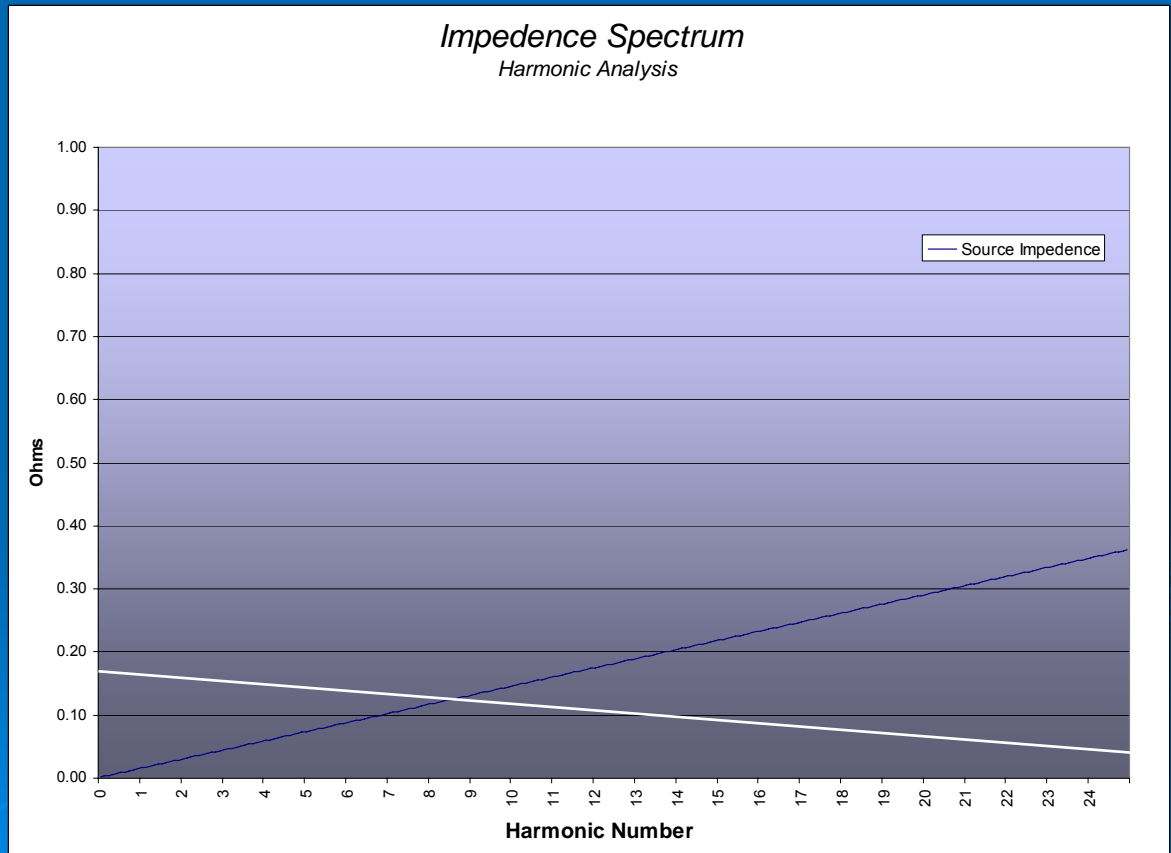
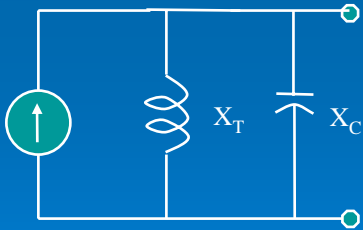

Source Issues

Norton Equivalent Circuit

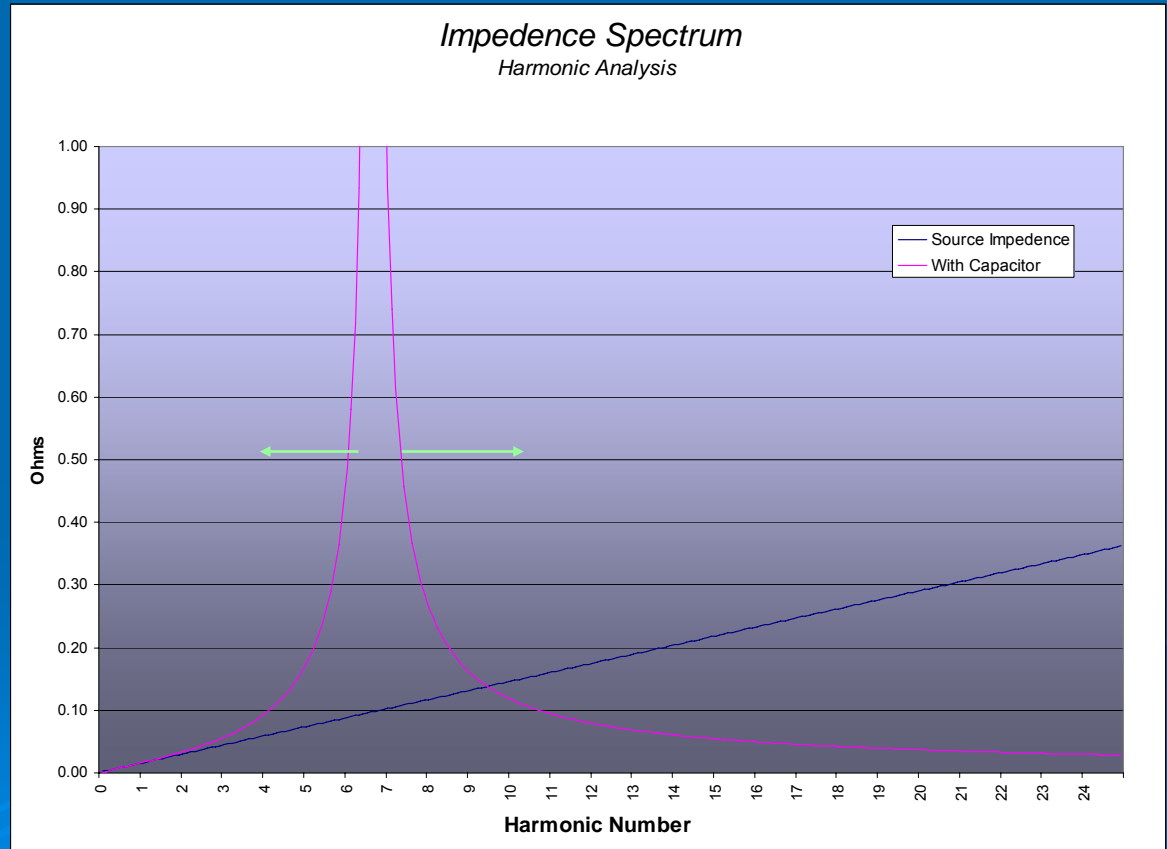
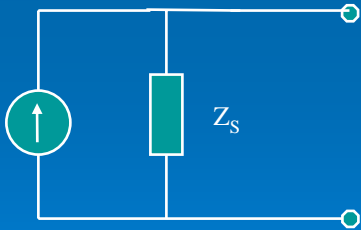

Source Issues

Norton
Equivalent Circuit

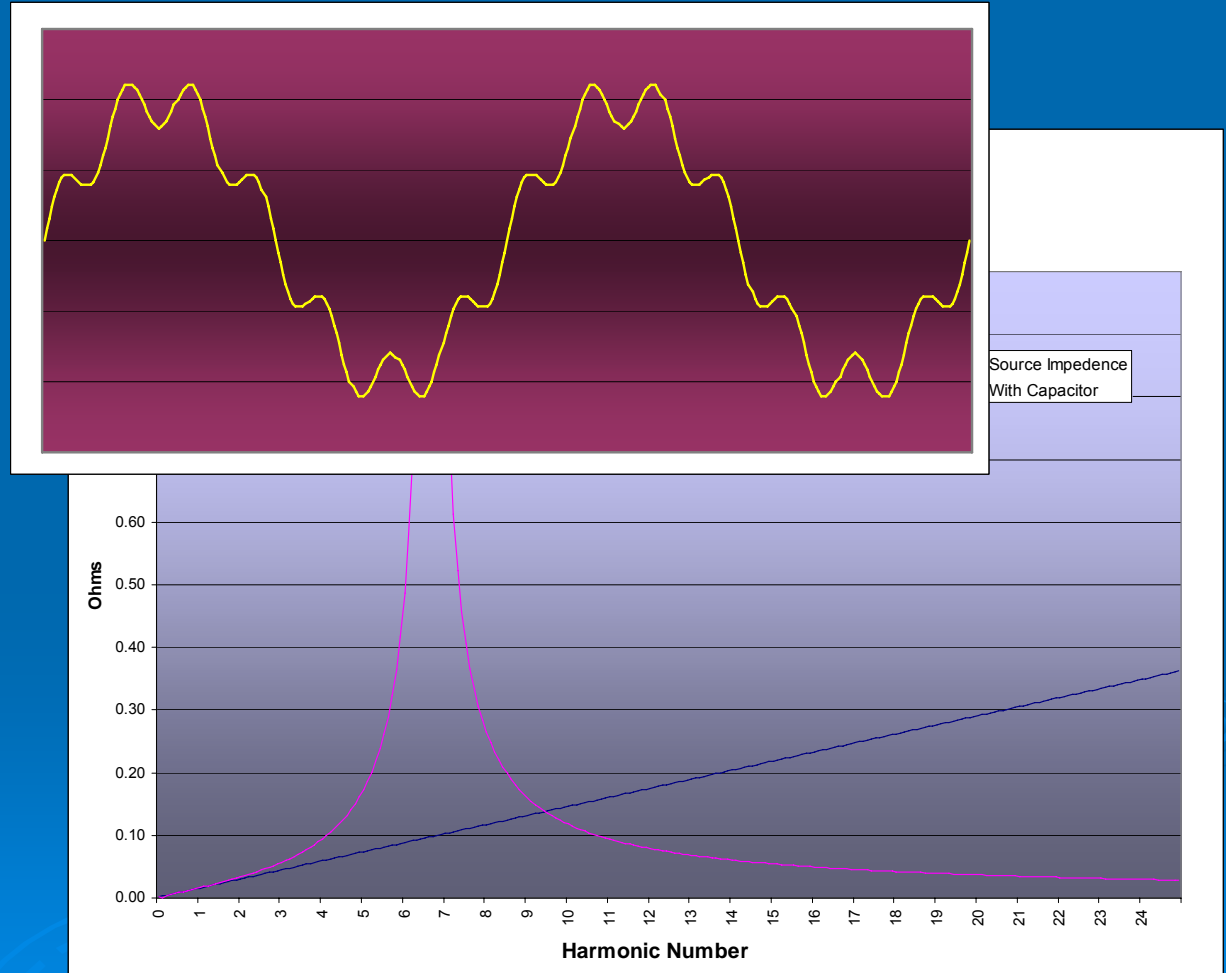
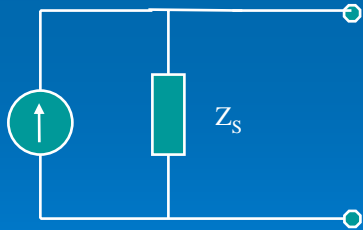

Source Issues

Norton Equivalent Circuit

$$X_L + X_C$$

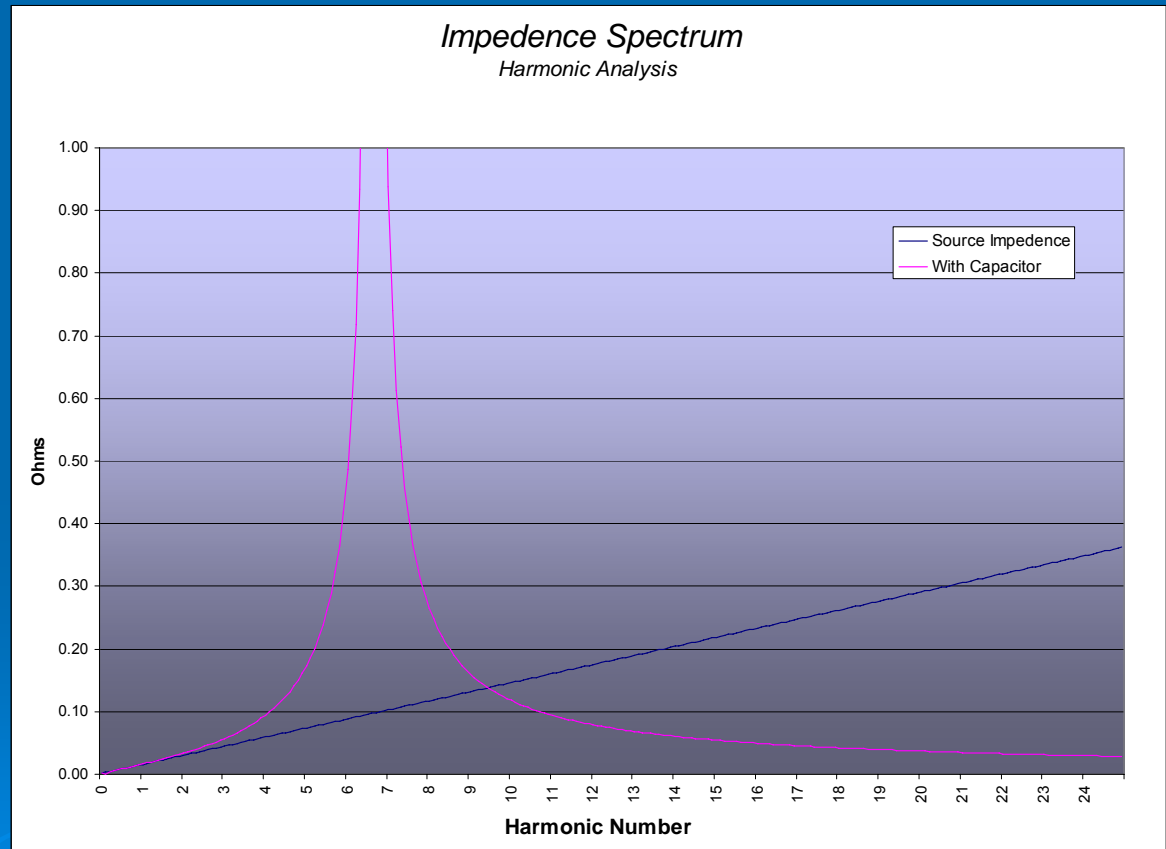
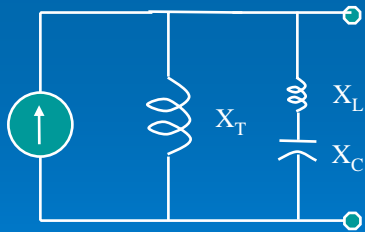

Source Issues

Norton Equivalent Circuit

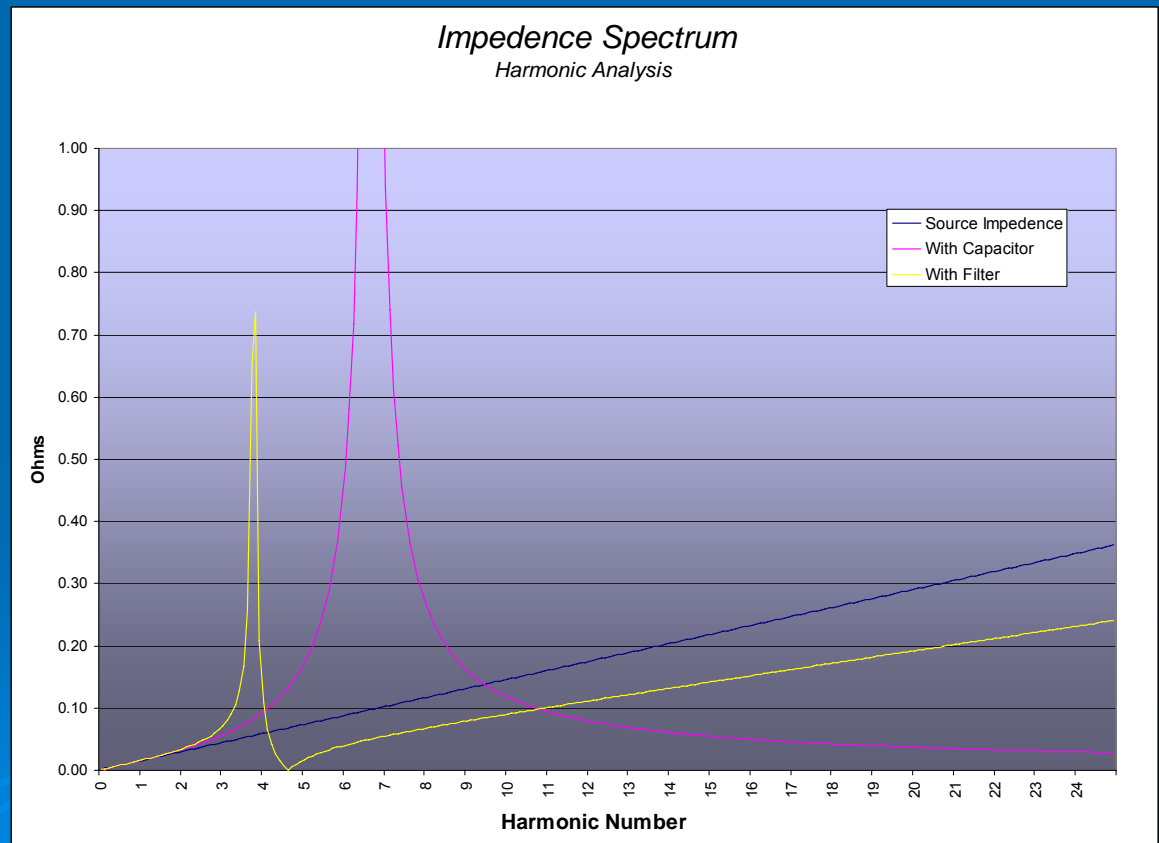
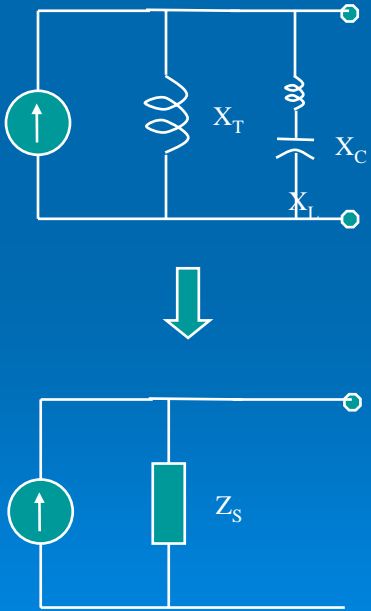

Tuning With Capacitors

Capacitor Tolerances

- In harmonic rich environments, capacitors form the low impedance path to source current
- In filter applications, capacitors also must tolerate higher voltages

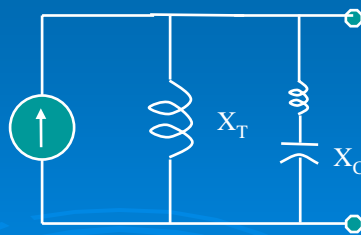

Tuning With Capacitors

Capacitor Tolerances

- United States: IEEE 18-2002
 - Capability
 - Line to Neutral 110% Continuous
 - Line to Line 120% Continuous
 - Current 180% Continuous
 - Var Output 135% Continuous
 - Europe: CE Standards call for 8 hour period
- Remember that these standards are ***Recommendations***, not *Code*, and can therefore be ignored by manufacturers

Tuning With Capacitors

➤ Capacitors - Two types

- Dry - usually polyester film dielectric
-  Oil Filled dielectric oil impregnated kraft paper
- Oil Filled – oil immersed polypropelene dielectric

Tuning With Capacitors

➤ Dry Type Capacitors

- Pros

- Inexpensive
- lightweight
- environmentally friendly

- Cons

- Do not meet IEEE 18-2002 standards
 - Short life in industrial applications
- Poor Thermal Characteristics
 - Short Life Cycle: 30,000 to 80,000 Hours *Within Ratings, Less Under Harsh Circumstances.*
 - Require frequent replacement (3 to 9 years)

Tuning With Capacitors

➤ Oil Filled Capacitors

- Pros:

- ***Tend*** to meet or exceed IEEE 18-2002 Standard
- Excellent Thermal Characteristics
 - Competent in harsh environments
 - Extremely long life - Typically 200,000 Hours
> 20 years

- Cons

- Environmental questions
 - Have approximately 8 oz fluid per cell (50 to 100 kvar)

Source Issues

- Power System is Basically Inductive
- Adding capacitance creates tuned system
- Careful tuning of capacitors can benefit system
- Tuning capacitors requires more robust capacitors

Power Factor Correction and Power System Harmonics



Eric Zobel
Myron Zucker, Inc.

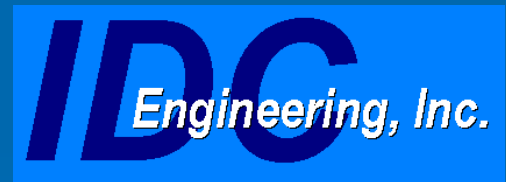

Julie VanDyne, P.E.
IDC Engineering, Inc.