



INSTALLATION INSTRUCTIONS FOR *CALMOUNT*[®] BRAND CAPACITORS

GENERAL

Congratulations! You have purchased the finest power capacitor available. All Myron Zucker, Inc. *Calmount*[®] brand capacitors are made with state-of-the-art metallized cells designed for low electrical loss and long life. All wiring, connectors and other components are top quality. Each capacitor is housed in a powder coat painted steel enclosure fitted with a gasketed cover designed to provide both protection and easy installation. To ensure that you obtain satisfactory service from your *Calmount*[®] brand capacitor, please follow these Installation Instructions.

Calmount[®] brand capacitors can be connected either at the load (Circuit 1) or on the line (Circuit 2). In Circuit 2, the capacitor must be connected through a disconnect device. Both circuits must have overcurrent protection. (For sizing, see chart on back of these Installation Instructions.)

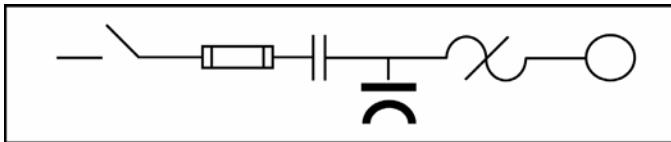

Circuit 1

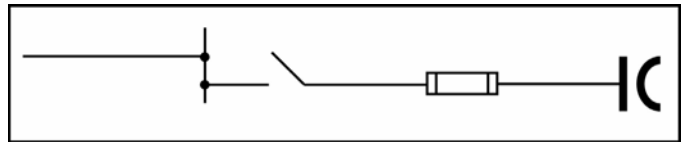

Circuit 2

Capacitor lifetime is greatly reduced at high temperatures. *Calmount*[®] brand capacitors should be installed in cool locations with good ventilation. Mechanical requirements of mounting the capacitor must also be considered. In general, when selecting a mounting location:

- Avoid obvious "hot spots", such as furnaces, transformers, heating ducts and direct sunlight.
- Avoid locations with harmonic voltages or currents.
- Allow at least three inches (3") around the capacitor for air circulation.
- Allow mechanical clearances for:
 - ducts and conduits (including future needs)
 - construction
 - machinery
 - opening doors
 - removal of the capacitor cover
- Position the capacitor for convenient nipping to cabinet or conduit and for visibility of indicator lights.
- Protect the capacitor from excessive dirt, dripping fluids and human interface.

LOCATION AMBIENT TEMPERATURE

Location ambient temperature is the temperature of the location before capacitors are installed, or with the capacitors installed but not operating (not energized). This is the temperature of the surrounding air in the room, vault, substation or enclosure where the capacitor will be operating. Maximum location ambient temperature should not exceed 46°C (115°F).

www.myronzucker.com

36825 Metro Court · Sterling Heights, MI 48312 | (800) 245-0583 | (586) 979-9955 | Fax (586) 979-9484

POWER ♦ QUALITY

REMOVE COVER

The cover on all **Calmount**[®] brand capacitors is held on by four (4) side screws, and on larger units, two (2) or more front panel screws.

To remove cover:

1. Take out front panel screws (if present).
2. Loosen side screws.
3. Lift cover off slightly.
4. Swing cover free from screws.
5. Lift cover off.

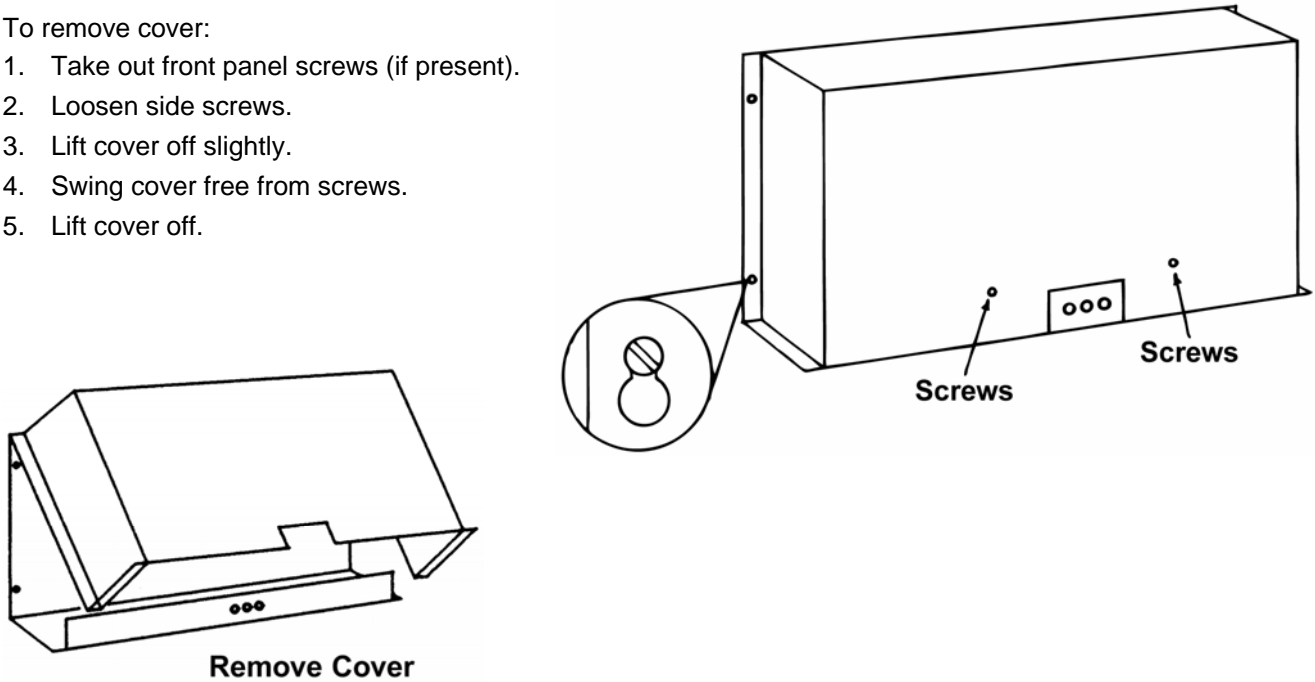

MOUNTING CALMOUNT[®] BRAND CAPACITORS

Place **Calmount**[®] brand capacitor on cabinet or wall, and mark mounting holes. (Mounting holes are prepunched on all **Calmount**[®] brand capacitors.)

The following illustration shows the locations for conduit entry:

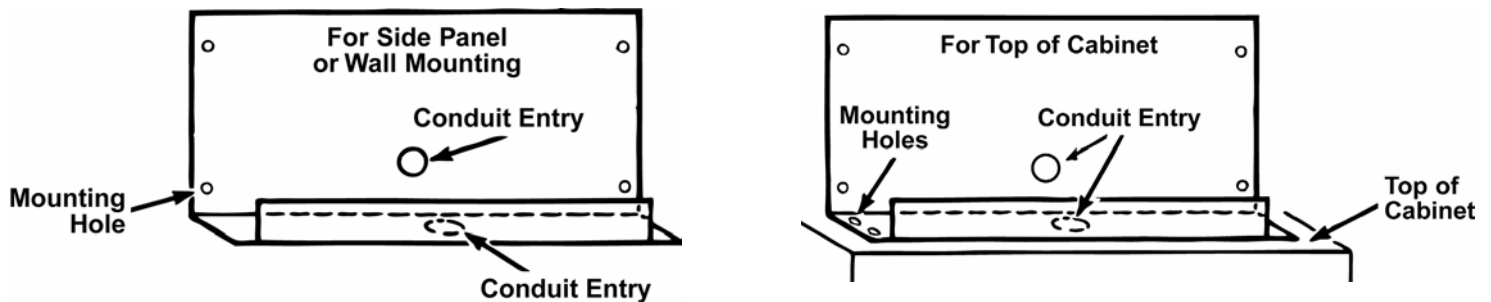

ATTACHING WIRES TO CALMOUNT® BRAND CAPACITORS

Select proper wire size from chart on back of these Installation Instructions.

Calmount® brand capacitors

Electrical connections to these capacitors are made either to a fuse block, fuse lugs, or to a distribution block. Connect a single-phase wire to each terminal. **Be sure to attach grounding wire to ground lug for safety.**

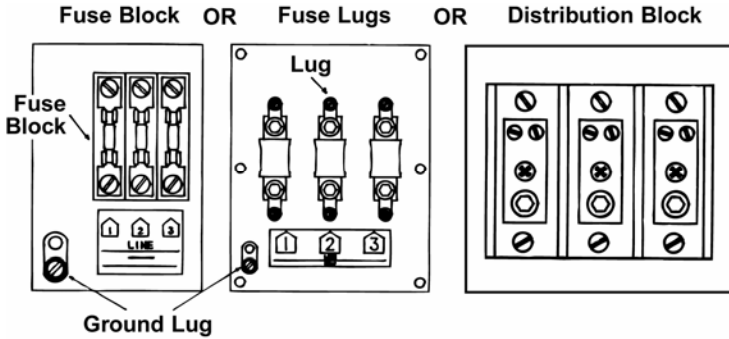

Multical® brand capacitors

On these units, each capacitor is wired to a separate fuse block.

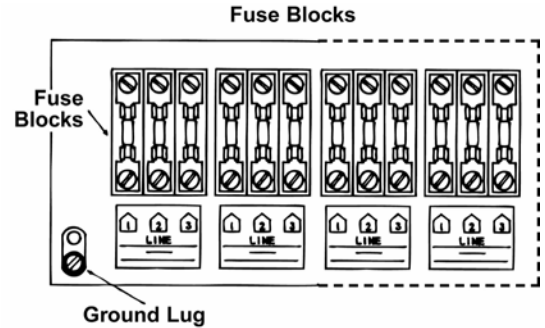

CALMOUNT® BRAND CAPACITOR WITH CONTACTOR OPTION (CIRCUIT 3)

A two position terminal strip is provided for the remote operation of the contactor. Ensure that the voltage being supplied to the contactor terminals is the same as the contactor coil.

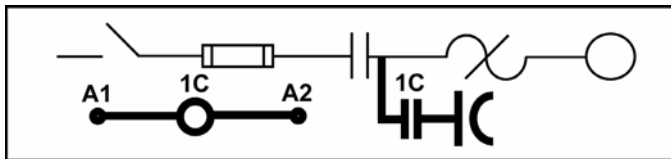

Circuit 3 (Contactor Option)

INDICATING LIGHTS

Calmount® brand capacitor - KIM Series

On the KIM series capacitors, there are two (2) red lights and one (1) amber light. The two red lights are for indicating blown fuses. The amber light serves two (2) indicating purposes:

- blown fuse – middle phase (L2)
- loss of capacitance in a capacitor cell detected by **CelTel®** brand indicator

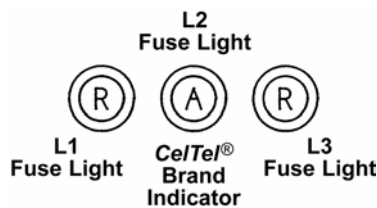

Calmount® brand capacitor - KNM Series

On the KNM series capacitors, there are three (3) red indicating lights for indicating blown fuses. If a fuse blows, the fuse light will illuminate. Each fuse light is wired in parallel to its fuse.

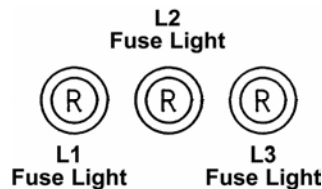

CAUTION:

USE COPPER CONDUCTORS ONLY. UNIT TERMINALS ARE NOT DESIGNED TO ACCEPT OTHER TYPE WIRING. THE USE OF ALUMINUM WIRING MAY CAUSE GALVANIC CORROSION AND/OR OVERHEATING AT THE CONNECTION POINTS WITH RESULTANT EQUIPMENT FAILURE.

RECOMMENDED WIRE SIZES, SWITCHES, AND FUSES FOR 3-PHASE 60HZ CAPACITORS

(These wire sizes are based on 135% of rated current in accordance with the National Electric Code, Article 460)

KVAR	240 VOLTS				480 VOLTS				600 VOLTS				KVAR
	Current* (Amps)	Wire Size 90°C-Type THHN XHHW* or Equip ‡	Fuse (Amps)	C.B. or Switch (Amps)	Current* (Amps)	Wire Size 90°C-Type THHN XHHW* or Equip ‡	Fuse (Amps)	C.B. or Switch (Amps)	Current* (Amps)	Wire Size 90°C-Type THHN XHHW* or Equip ‡	Fuse (Amps)	C.B. or Switch (Amps)	
1	2.4	14	5	30	1.2	14	3	30	1.0	14	3	30	1
1.5	3.6	14	6	30	1.8	14	3	30	1.4	14	3	30	1.5
2	4.8	14	10	30	2.4	14	5	30	1.9	14	3	30	2
2.5	6	14	10	30	3	14	6	30	2.4	14	5	30	2.5
3	7.2	14	15	30	3.6	14	6	30	2.9	14	5	30	3
4	9.6	12	20	30	4.8	14	10	30	3.8	14	6	30	4
5	12	12	20	30	6	14	10	30	4.8	14	10	30	5
6	14.4	10	25	30	7.2	14	15	30	5.8	14	10	30	6
7.5	18	10	30	30	9	14	15	30	7.2	14	15	30	7.5
10	24	8	40	60	12	12	20	30	9.6	12	20	30	10
12.5	30	8	50	60	15	10	25	30	12	12	20	30	12.5
15	36	6	60	60	18	10	30	30	14.4	10	25	30	15
17.5	42	6	70	100	21	8	35	60	16.8	10	30	30	17.5
20	48	4	80	100	24	8	40	60	19.2	8	35	60	20
22.5	54	4	90	100	27	8	50	60	21.6	8	35	60	22.5
25	60	2	100	100	30	8	50	60	24	8	40	60	25
27.5	66	2	125	200	33	6	60	60	26.4	8	45	60	27.5
30	72	2	125	200	36	6	60	60	28.8	8	50	60	30
32.5	78	1/0	150	200	39	6	65	100	31.2	8	50	60	32.5
35	84	1/0	150	200	42	6	70	100	33.6	6	60	60	35
37.5	90	1/0	150	200	45	6	75	100	36	6	60	60	37.5
40	96	2/0	175	200	48	4	80	100	38.4	6	65	100	40
42.5	102	2/0	175	200	51	4	90	100	40.8	6	70	100	42.5
45	108	3/0	200	200	54	4	90	100	43.2	6	75	100	45
50	120	3/0	200	200	60	2	100	100	48	4	80	100	50
52.5	126	3/0	200	200	63	2	110	200	50.4	4	80	100	52.5
55	132	4/0	250	400	66	2	125	200	52.8	4	90	100	55
60	144	4/0	250	400	72	2	125	200	57.6	2	100	100	60
65	156	4/0	250	400	78	1/0	150	200	62.4	2	110	200	65
70	168	300M	300	400	84	1/0	150	200	67.2	2	125	200	70
75	180	300M	300	400	90	1/0	150	200	72	2	125	200	75
80	192	350M	350	400	96	2/0	175	200	76.8	1/0	150	200	80
90	216	500M	400	400	108	3/0	200	200	86.4	1/0	150	200	90
100	240	500M	400	400	120	3/0	200	200	96	2/0	175	200	100
125	300	(2)4/0	500	600	150	4/0	250	400	120	3/0	200	200	125
150	360	(2)300M	600	600	180	300M	300	400	144	4/0	250	400	150
200	480	(2)500M	800	800	240	500M	400	400	192	350M	350	400	200
225	540	(3)300M	900	1200	270	(2)4/0	500	600	216	500M	400	400	225
250	600	(3)350M	1000	1200	300	(2)4/0	500	600	240	500M	400	400	250
300	720	(3)500M	1200	1200	360	(2)300M	600	600	288	(2)4/0	500	600	300
350					420	(2)350M	700	800	336	(2)300M	600	600	350
400					480	(2)500M	800	800	384	(2)350M	700	800	400
450					540	(3)300M	900	1200	432	(2)400M	750	800	450
500					600	(3)350M	1000	1200	480	(2)500M	800	800	500
550					660	(3)500M	1100	1200	528	(3)300M	900	1200	550
600					720	(3)500M	1200	1200	576	(3)350M	1000	1200	600

*Rated current based on operation at rated voltage, frequency and KVAR

‡ Consult National Electric Code (NEC) for other wire types above size based on 35°C ambient operation (refer to NEC Table 310-16)

Note: Fuses furnished within capacitor assembly may be at higher value than shown in this table. The table is correct for field installation and reflects the manufacturer's suggested rating for overcurrent protection and disconnect means in compliance with the NEC.