

MYRON ZUCKER^{INC.}

LINE REACTOR MANUAL



WHAT IS A LINE REACTOR?

A 3 phase Line Reactor is a set of three (3) coils (also known as windings, chokes or inductors) in one assembly. It is a series device, which means it is connected in the supply line such that all line current flows through the reactor, as shown below.

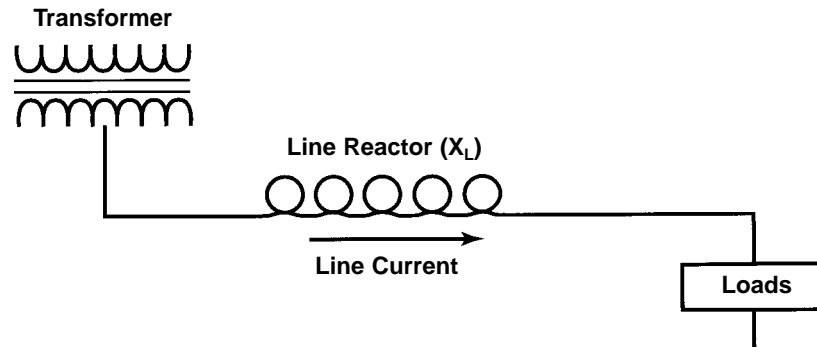

Line Reactors are current-limiting devices and oppose rapid changes in current because of their impedance. They hold down any spikes of current and limit any peak currents. This resistance to change is measured in ohms as the Line Reactor's AC impedance (X_L) and is calculated as follows:

$$X_L = 2 \pi f L \text{ (ohms)}$$

f = frequency in hertz (cycles per second)

harmonic frequency examples:

harmonic (60 Hz)	frequency (Hz)
5th	300
7th	420
11th	660

L = reactor inductance in henries (H), millihenries (mH) — $H \times 10^{-3}$, microhenries (μH) — $H \times 10^{-6}$

By inspection of the X_L formula, the Line Reactor impedance is directly proportional to the frequency (f) and the inductance (L). That is, if the impedance of a Line Reactor is 10 ohms at 60 Hz, then at the 5th harmonic (300 Hz) the impedance is 50 ohms. If the inductance (L) is increased, then the impedance will increase proportionally.

This increase in Line Reactor impedance will reduce the current in the line. The higher the frequency (Hertz), the lower the current. A Line Reactor's DC resistance (R -ohms) is very low by design so that the power losses (watts- I^2R) are low.

Line Reactors are rated by % impedance, voltage and current. However, they are sized by % impedance, voltage and motor horsepower. The motor horsepower determines the necessary current rating for the Line Reactor.



Line Reactors are rated by impedance, voltage and current.

1. Impedance (% impedance of load Z)

The load impedance (Z) is calculated by this formula:

$$Z = \frac{V}{I} \quad \text{where: } \begin{array}{l} \mathbf{Z} = \text{load impedance (ohms)} \\ \mathbf{V} = \text{line voltage (volts)} \\ \mathbf{I} = \text{line current (amps)} \end{array}$$

This percent of load impedance also determines the voltage drop across the Line Reactor. For example, a 5% Line Reactor would have a 5% voltage drop.

2. Voltage rating

Since a Line Reactor is a current-sensitive device, the voltage rating is needed for dielectric concerns as a maximum voltage and horsepower. It is also used to determine the current rating when given only voltage and horsepower.

3. Current rating (amperes)

This is the current required by the load(s). It is total current flowing to the load(s) and through the reactor. This current is measured in amperes (amps).

WHAT DEVICES REQUIRE LINE REACTORS?

Variable Frequency Drives, DC drives, SCR drives and Rectifier drives for motors are some of the names for devices that require Line Reactors. These are grouped together and termed Adjustable Speed Drives (ASDs) to encompass any type of drive for a motor which changes the output speed. This happens because the current waveform is changed, creating a non-sinusoidal waveform. Our Line Reactors are sized so that they can be used on the input and the output side of drives.

WHY ARE LINE REACTORS USED?

Until about 10 years ago, isolation transformers (1 to 1 ratio) were used to control power transients, provide line protection and isolate loads. Line Reactors accomplish these functions, and more, at a lower cost and a smaller physical size. They are excellent at providing isolation of the drive from the power system. This is important because many times multiple drives are located near each other and cause interference between each other. Line Reactors are used to reduce voltage notching caused by the rapid change in current draw by ASDs. They also provide short-circuit protection and reduce spikes, sags and harmonics. Harmonics are currents flowing at frequencies which are multiples of the fundamental frequency (usually 60 Hz). All our Line Reactors are "Harmonic-Compensated" units. This allows them to be used in any application.

WHERE AND HOW ARE LINE REACTORS CONNECTED?

If used on the output side of a drive, the Line Reactor is connected in series with the motor leads which run from the drive to the motor.

If used on the input side of a drive for non-harmonic applications (a Trap/filter is not used), then the Line Reactor is connected in series with the power leads to the drive and should be on the load side of the drive disconnect.

If used on the input side of a drive motor for harmonic applications (a Trap/filter is used), then the Line Reactor is connected in series with the power leads to the drive and on the line side of the Trap/filter.

Our 3 phase Line Reactors are connected by three (3) input terminals labeled "A1," "B1" and "C1" for the line side and three (3) output terminals labeled "A2," "B2" and "C2." These terminals are uniquely designed with a heavy-duty plastic shield covering them.

TYPICAL APPLICATIONS

Case 1

Nuisance Problems

- Current surge
- Voltage transients
- Drive nuisance tripping
- Voltage notching
- High-voltage spikes from capacitor switching
- Multiple motor applications on the same bus

Recommendation: Select a 3% Line Reactor sized per the voltage and horsepower from the Myron Zucker, Inc. catalog. Connect on the input as follows:

If used on the input side of a drive for non-harmonic applications (a Trap/filter is not used), then the Line Reactor is connected in series with the power leads to the drive and should be on the load side of the drive disconnect.

Case 2

Motor Drive Problems

- Motor temperature
- Motor noise
- Motor efficiency improvement

Recommendation: Select a 5% Line Reactor sized per the voltage and horsepower from the Myron Zucker, Inc. catalog. Connect on the output as follows:

If used on the output side of a drive, the Line Reactor is connected in series with the motor leads which run from the drive to the motor.

Case 3

Motor Drive — Harmonic Reduction — No Power Factor Penalty Imposed by Utility

For harmonic reduction on motor drive circuits with no power factor correction capacitors on the secondary side of the industrial plant transformer and no power factor penalty imposed by the utility company, use the following:

Recommendation: Select a 5% Line Reactor sized per the voltage and horsepower from the Myron Zucker, Inc. catalog. Connect on the input as follows:

If used on the input side of a drive for non-harmonic applications (a Trap/filter is not used), then the Line Reactor is connected in series with the power leads to the drive and should be on the load side of the drive disconnect.

Case 4

Motor Drive — Harmonic Reduction — Power Factor Penalty Imposed by Utility

In plants which have power factor penalties and power factor correction capacitors are installed, or there are plans to install power factor correction capacitors, the following should be used:

If existing power factor correction capacitors are installed and Adjustable Speed Drives (ASDs) are being added, then harmonic filters must be installed on each ASD or group of ASDs. Contact Myron Zucker, Inc. regarding Traps/filters and their applications. To isolate the in-plant power factor correction capacitors, a Line Reactor must be installed on the line side of the harmonic Trap/filter.

Recommendation: Select a 5% Line Reactor sized per the voltage and horsepower from the Myron Zucker, Inc. catalog. Connect on the input as follows:

If used on the input side of a drive for harmonic applications (a Trap/filter is used), then the Line Reactor is connected in series with the power leads to the drive and on the line side of the Trap/filter.

MYRON ZUCKER INC

36825 Metro Court
Sterling Heights, MI 48312-1013
www.myronzucker.com

Phone: (586) 979-9955
(800) 245-0583
Fax: (586) 979-9484

