

MYRON  ZUCKER

---

*AUTOCAPACIBANK™ and AUTOCAPACITRAP™*

**INSTALLATION AND OPERATIONS MANUAL**

## NOTE

Please read this entire installation and operations manual before energizing the AUTOCAPACIBANK™ or AUTOCAPACITRAP™.



### Safety Considerations:

- Installing and servicing capacitor equipment can be hazardous. Only trained personnel should install and service power factor correction capacitors and harmonic filters.
- Observe precautions in the literature, on tags, and on labels attached to the equipment.
- Follow all safety codes such as Lock-out/Tag-out procedures, Arc Flash safety, etc.
- Wear required Personal Protective Equipment (PPE) such as safety glasses, work gloves, cotton clothing, etc. as required by local code and safety procedures.



### Warnings and Cautions:

- Power factor correction capacitors **alone** are not for use in power systems where harmonic currents are present. Harmonic currents can overload a capacitor with excess current and/or heat. Harmonic currents should be corrected with Myron Zucker, Inc. Capacitrap® and Autocapacitrap™ models.
- Failure to read these instructions and failure to install the equipment per instructions may cause equipment damage and may void the warranty.
- Care should be taken in keeping the inside of enclosures clear of any debris, metalworking by-products or electrician's tools.
- It is recommended that incoming power be disconnected at the source before making any electrical or mechanical connections, changes or hands-on inspections.
- To de-energize capacitor cells, wait one minute after disconnecting the equipment from the primary circuit to allow capacitor discharge resistors to reduce capacitor voltage to less than 50 volts (National Electrical Code, Article 460-6 requirement).

## TABLE OF CONTENTS

<b>1. PRE-INSTALLATION</b> .....	1
1.1 Storage .....	1
1.2 Location .....	1
<b>2. POWER SOURCE</b> .....	2
2.1 Voltage .....	2
2.2 Conductor (Wire) Size .....	2
2.3 Disconnect Devices and Ratings .....	2
2.4 Connections to Power Source .....	2
2.5 Equipment Ground .....	2
<b>3. CURRENT TRANSFORMER</b> .....	4
3.1 Selection of Current Transformer .....	4
3.2 Placement of Current Transformer .....	4
<b>4. COMMISSIONING AND VAR CONTROLLER INSTRUCTIONS</b> .....	5
4.1 Overview of VAR Controller .....	5
4.2 Pre-commissioning Procedure .....	6
4.3 Operating Instructions for Autocapacibank™ and Autocapacitrap™ ..	6
<b>5. PREVENTATIVE MAINTENANCE PROCEDURES</b> .....	8

## TABLES AND FIGURES

<b>TABLE 1. Recommended Wire Sizes, Switches And Fuses</b> .....	3
<b>FIGURE 1. Connection to Power Source Diagram</b> .....	2
<b>FIGURE 2. VAR Controller – LOVATO Type DCRG8</b> .....	5

## 1. PRE-INSTALLATION

Inspect the equipment for any damage as soon as it is received. All risk of loss or damage in transit shall pass to the purchaser at the shipping point, regardless of freight payment.

- Check that all packages and/or crates have been delivered and that the equipment has not been damaged in transit.
- Forward any claims to the carrier immediately (most carriers impose a 24-hour time limit for the reporting of loss or damage).
- Damaged or missing items are the responsibility of the carrier and must be reported.
- Check that the information shown on the equipment nameplates corresponds with the order specifications.
- The packaging material should be replaced for protection until installation has begun.

### 1.1 Storage

If the equipment cannot be placed into service reasonably soon after its receipt, it should be stored in a clean, dry and ventilated building free from temperature extremes. Acceptable storage temperatures are from 0°C (32°F) to 40°C (104°F).

- Store the equipment in a dry, ventilated location, sheltered from rain, water spray, splashes and chemicals.
- Stored equipment should be protected by a tarp or other cover providing effective protection against dust, dirt, paint, etc.

### 1.2 Location

Installation ambient temperatures are very important to achieve design life of equipment.

- Suggested location maximum ambient temperature is 40°C (104°F).
- Maximum capacitor operating ambient temperature shall be 46°C (115°F).
- For outdoor enclosures, care must be taken to keep equipment from direct sunlight and other weather conditions.
- Spacing from walls shall be six (6) inches and twelve (12) inches from overheads. All other equipment, housings, cabinets or other obstructions shall be considered as walls or overheads.

## 2. POWER SOURCE

### 2.1 Voltage

Check the equipment's nameplate to make certain that the voltage rating is suitable for operation at the supply (line) voltage. This equipment is capable of operation at a maximum of 110% of nameplate rated voltage (RMS, 50 or 60 Hz).

### 2.2 Conductor (Wire) Size

See **TABLE 1** on next page for recommended wire size.

### 2.3 Disconnect Devices and Ratings

Equipment shall be capable of being disconnected from power source with switch, fuse switch or circuit breaker. See **TABLE 1** for recommended current ratings.

### 2.4 Connections to Power Source

Equipment shall be connected to power source as shown in **FIGURE 1**.

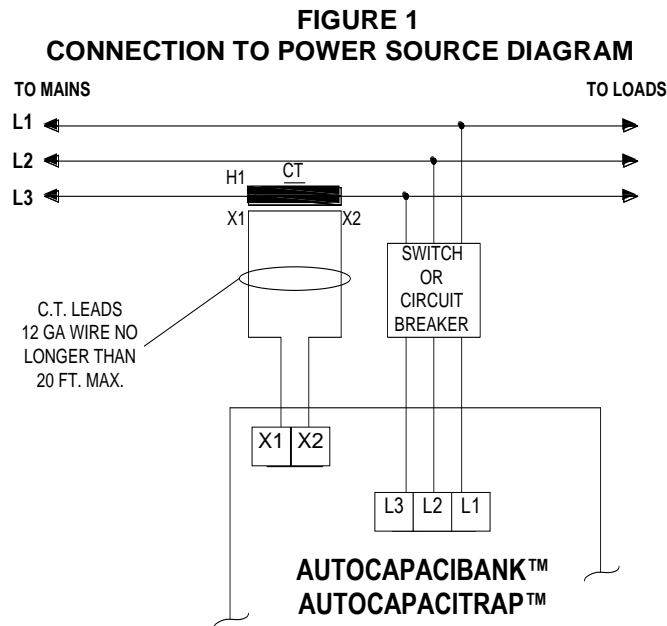

Power leads shall be straight and without kinks or loops. Lead length should be such that no strain is applied to the power lead connector. Power leads shall be firmly clamped in connectors by tightening connector bolts. Wire lead strands should not move in connector when the lead is moved from side to side by hand. Improper (loose) connections will cause terminal overheating and possible early failure of the capacitor cells.

### 2.5 Equipment Ground

All Autocapacibanks™ and Autocapacitraps™ are provided with ground connector lug(s) within the enclosure to facilitate grounding per National Electrical Code, Articles 460-10 & 250.

**TABLE 1**  
**RECOMMENDED WIRE SIZES, SWITCHES AND FUSES FOR 3-PHASE, 60Hz CAPACITORS**

(These wire sizes are based on 135% of rated current in accordance with the National Electrical Code, Article 460.)

KVAR	240 VOLTS				480 VOLTS				600 VOLTS			
	Current* (Amps)	Wire Size 90°C-Type THHN XHHW* or Equiv. †	Fuse (Amps)	C.B. or Switch (Amps)	Current* (Amps)	Wire Size 90°C-Type THHN XHHW* or Equiv. †	Fuse (Amps)	C.B. or Switch (Amps)	Current* (Amps)	Wire Size 90°C-Type THHN XHHW* or Equiv. †	Fuse (Amps)	C.B. or Switch (Amps)
1	2.4	14	5	30	1.2	14	3	30	1.0	14	3	30
1.5	3.6	14	6	30	1.8	14	3	30	1.4	14	3	30
2	4.8	14	10	30	2.4	14	5	30	1.9	14	3	30
2.5	6	14	10	30	3	14	6	30	2.4	14	5	30
3	7.2	14	15	30	3.6	14	6	30	2.9	14	5	30
4	9.6	12	20	30	4.8	14	10	30	3.8	14	6	30
5	12	12	20	30	6	14	10	30	4.8	14	10	30
6	14.4	10	25	30	7.2	14	15	30	5.8	14	10	30
7.5	18	10	30	30	9	14	15	30	7.2	14	15	30
10	24	8	40	60	12	12	20	30	9.6	12	20	30
12.5	30	8	50	60	15	10	25	30	12	12	20	30
15	36	6	60	60	18	10	30	30	14.4	10	25	30
17.5	42	6	70	100	21	8	35	60	16.8	10	30	30
20	48	4	80	100	24	8	40	60	19.2	8	35	60
22.5	54	4	90	100	27	8	50	60	21.6	8	35	60
25	60	2	100	100	30	8	50	60	24	8	40	60
27.5	66	2	125	200	33	6	60	60	26.4	8	45	60
30	72	2	125	200	36	6	60	60	28.8	8	50	60
32.5	78	1/0	150	200	39	6	65	100	31.2	8	50	60
35	84	1/0	150	200	42	6	70	100	33.6	6	60	60
37.5	90	1/0	150	200	45	6	75	100	36	6	60	60
40	96	2/0	175	200	48	4	80	100	38.4	6	65	100
42.5	102	2/0	175	200	51	4	90	100	40.8	6	70	100
45	108	3/0	200	200	54	4	90	100	43.2	6	75	100
50	120	3/0	200	200	60	2	100	100	48	4	80	100
52.5	126	3/0	200	200	63	2	110	200	50.4	4	80	100
55	132	4/0	250	400	66	2	125	200	52.8	4	90	100
60	144	4/0	250	400	72	2	125	200	57.6	2	100	100
65	156	4/0	250	400	78	1/0	150	200	62.4	2	110	200
70	168	300M	300	400	84	1/0	150	200	67.2	2	125	200
75	180	300M	300	400	90	1/0	150	200	72	2	125	200
80	192	350M	350	400	96	2/0	175	200	76.8	1/0	150	200
90	216	500M	400	400	108	3/0	200	200	86.4	1/0	150	200
100	240	500M	400	400	120	3/0	200	200	96	2/0	175	200
125	300	(2)4/0	500	600	150	4/0	250	400	120	3/0	200	200
150	360	(2)300M	600	600	180	300M	300	400	144	4/0	250	400
200	480	(2)500M	800	800	240	500M	400	400	192	350M	350	400
225	540	(3)300M	900	1200	270	(2)4/0	500	600	216	500M	400	400
250	600	(3)350M	1000	1200	300	(2)4/0	500	600	240	500M	400	400
300	720	(3)500M	1200	1200	360	(2)300M	600	600	288	(2)4/0	500	600
350					420	(2)350M	700	800	336	(2)300M	600	600
400					480	(2)500M	800	800	384	(2)350M	700	800
450					540	(3)300M	900	1200	432	(2)400M	750	800
500					600	(3)350M	1000	1200	480	(2)500M	800	800
550					660	(3)500M	1100	1200	528	(3)300M	900	1200
600					720	(3)500M	1200	1200	576	(3)350M	1000	1200

\* Rated current based on operation at rated voltage, frequency, and KVAR.

†Consult National Electrical Code for other wire types. Above size based on 35°C Ambient Operation. (Refer to NEC table 310-16)

**Note:** Fuses furnished within Capacitor Assembly may be rated at higher value than shown in this table. The table is correct for field installations and reflects the manufacturer's suggested rating for overcurrent protection and disconnect means in compliance with the National Electrical Code.

**3. CURRENT TRANSFORMER** The CT provides a feedback signal required for the operation of the power factor controller.

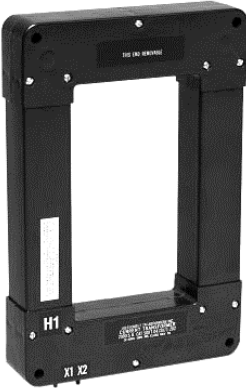

**3.1 Placement of Current Transformer**

- As shown in **FIGURE 1**, the CT must be placed on the C or L3 Phase upstream of all loads and capacitor banks (see below).
- The X1 and X2 terminals for the CT have a shorting, knife-type, terminal that is installed at the factory. This terminal must remain closed until the CT wires have been connected then it must be opened and remain open.
- H1 side of CT must face toward the mains.

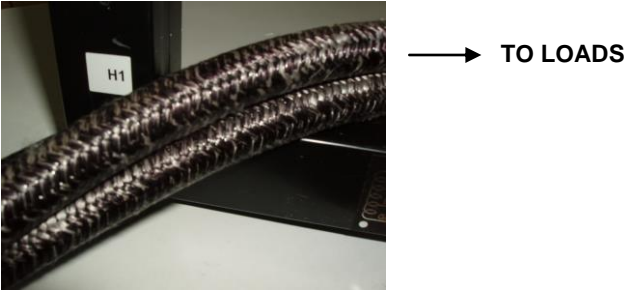

**Proper CT Location Examples on an Electrical System**

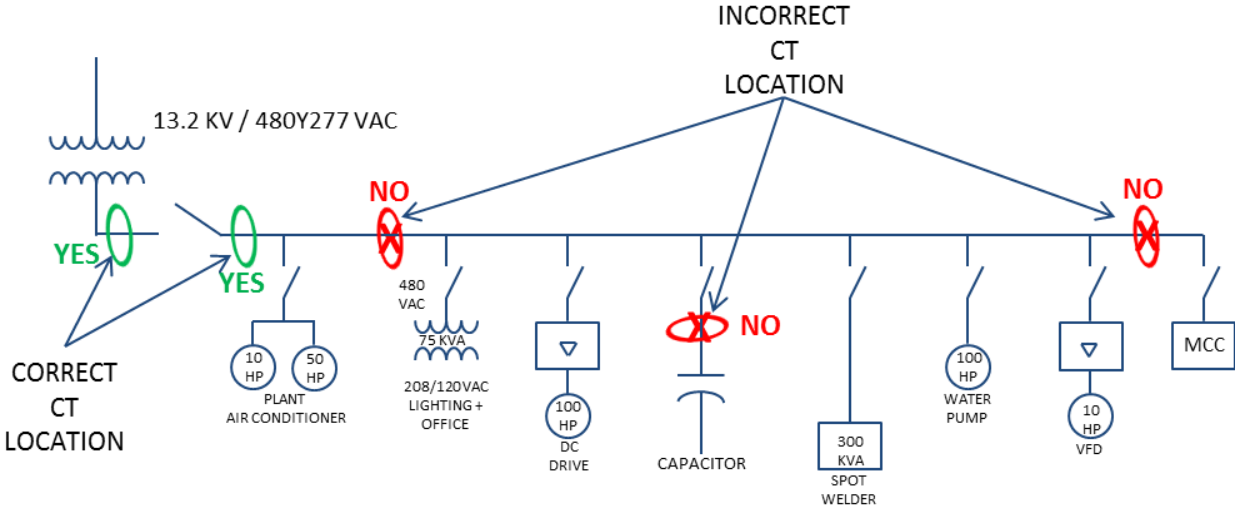

**WITHOUT A SHORTING TERMINAL VERY HIGH VOLTAGES CAN BE PRODUCED AT TERMINALS X1 AND X2 OF THE CURRENT TRANSFORMER.**

**CT MUST BE PLACED ON THE 'C' OR 'L3' PHASE BETWEEN THE MAIN AND LOADS ON THE MAIN SIDE OF THE CAPACITOR UNIT.**

## 4. COMMISSIONING AND VAR CONTROLLER INSTRUCTIONS

### 4.1 Overview of VAR Controller

The VAR Controller is a power factor relay device (microprocessor-controlled) and is factory set and tested on all equipment. It measures all four quadrants of the power waveform, and is consequently independent of system harmonics. The VAR Controller also actuates the switching steps to control the power factor. For detailed information regarding the functions of the VAR Controller, please contact our technical department at (800) 245-0583.

**FIGURE 2**  
**VAR CONTROLLER – LOVATO TYPE DCRG8**



When the current transformer (CT) is supplied by the factory, the VAR controller is pre-programmed to make startup simpler.

**Note:** If the CT is not supplied with the equipment, you will need to program the CT ratio in the General Section of the controller, program #P02.01.

**Note:** At least 10% inductive load is required on the main switchboard in order to commission the system.



## 4.2 Pre-commissioning Procedure



**The AUTOCAPACIBANK™ and AUTOCAPACITRAP™ should only be commissioned by qualified electricians or technicians who have read this manual and the materials which were shipped with the unit.**

The commissioning procedure, once the pre-startup checks have been done, consists of energizing the capacitor bank and observing that the capacitor stages are automatically connected one-by-one until the power factor (cos $\phi$ ) displayed on the VAR Controller display reads 0.95 IND or greater depending upon the target power factor programmed.



**This equipment must be de-energized prior to inspection before commissioning. Electrically isolate the equipment and implement proper lock-out and tag-out procedures. Failure to observe this exercise will result in hazard of electrical shock or burn.**

The equipment must be inspected using the following procedure by a qualified electrician or technician prior to energizing to ensure that it is ready for startup:

- Make sure that the equipment is de-energized.
- Make sure that the main breaker feeding the equipment is open.
- Confirm that the main power cables have been connected and torqued.
- Confirm that the CT has been installed on phase C (L3) of the main switchboard.
- Short the CT using the shorting terminal located on the terminal strip.



## 4.3 Autocapacibank™ or Autocapacitrap™ Operating Instructions

- Ensure the Autocapacibank™ or Autocapacitrap™ is connected in accordance with wiring diagram (**FIGURE 1**).
- Confirm that the electrical service that the equipment is connected to is operational at normal load.

- Open the CT shorting terminal and confirm that there is current on the CT secondary wires using a clamp-on ammeter.

**Note:** The CT knife switch terminal must be open for the VAR Controller to operate.

- Energize the Autocapacibank™ or Autocapacitrap™ by closing the main breaker or disconnect feeding the equipment.
- Confirm that there is correct voltage on L1, L2 and L3.
- Wait for 60-second lock-out time to elapse. During this time steps will not be activated.
- If the installation is correctly connected, the VAR Controller will now switch successive steps, following the selected step time delay until the target power factor is obtained. Each energized step will be indicated on the LCD Display (4 in **FIGURE 2**). As each step switches in/out the digital display of power factor will change.
- The LOVATO VAR Controller does not require any adjustment of C/K-value (threshold level when to start to switch in/out steps), since the step sizes will be sensed automatically. The controller will select a suitable capacitor in order to achieve the target. With equal sized capacitor steps the controller distributes the switching operations equally to the capacitors.
- A flashing display segment indicates that the relay is searching for a suitable capacitor size (inductive or capacitive) in order to meet the required target power factor. If no suitable size is available, then no switching will take place, and the segment will continue to flash until the power factor is obtained.

**Note:** Due to delays programmed into the VAR Controller, it may take up to 10 minutes for all the contactors to energize.

- At this point, the display will read the load power factor and indicate which capacitor stages are connected.
- If the load power factor is at or above the controller power factor set-point, then the commissioning is finished.
- If the power factor remains low, even though some or all of the stages have been energized, or if the display shows a capacitive power factor even though no stages have been energized, then a re-check of correct wiring must be completed.

## 5. PREVENTATIVE MAINTENANCE PROCEDURES

### **WIRE CONNECTIONS**

All power wire connections should be inspected for tightness one (1) month after commissioning and every six (6) months thereafter.

### **CAPACITOR CELLS**

Capacitor cells should be visually checked for distorted tops one (1) month after commissioning and every six (6) months thereafter.

### **INDICATION LIGHTS**

Blown fuse indication lights may be checked daily.

### **CLEANLINESS**

Every six (6) months the fan filters should be inspected and cleaned or replaced and the equipment should be clean of all contaminants. Note: DO NOT USE HIGH PRESSURE LIQUID TO CLEAN UNITS.

### **CONTACTORS**

Remove covers and visually check contacts for signs of wear and excessive arcing every six (6) months. Energize each contactor with the controller in "manual" mode to ensure proper operation.

### **INDUCTORS (AUTOCAPACITRAP™ UNITS ONLY)**

Inductors should be inspected for signs of heating or loose wire connections one (1) month after commissioning and every six (6) months thereafter. High temperature fault lights should be checked daily.

**[www.myronzucker.com](http://www.myronzucker.com)**

36825 Metro Court · Sterling Heights, MI 48312 | (800) 245-0583 | (586) 979-9955 | Fax (586) 979-9484

---

**POWER ♦ QUALITY**

©2009 Myron Zucker, Inc., All Rights Reserved